

INSTALLER AND OWNER GUIDE

Model 951 Heat Engine

INSET LIVE FUEL EFFECT GAS FIRE

This heat engine is designed for use with approved cast fascias and spacer frame / fret combinations.

(GC No. 32-032-75)



For further advice please contact the retailer or company from where you purchased your fire

INSTALLER: Please leave this guide with the owner

THIS APPLIANCE IS FOR USE WITH NATURAL GAS (G20).

**WHEN CONVERTED USING CONVERSION KIT NO. 0595211 THIS APPLIANCE
IS FOR USE WITH PROPANE GAS (G31).**

**THIS APPLIANCE IS SUITABLE ONLY FOR INSTALLATION IN THE UNITED
KINGDOM (GB) AND THE REPUBLIC OF IRELAND (IE).**

© Baxi Heating U.K. Limited 2010.

All rights reserved. No part of this publication may be reproduced in any material form (including photocopying), stored in any medium by electronic means (including in any retrieval system or database) or transmitted, in any form or by any means, whether electronic, mechanical, recording or otherwise, without the prior written permission of the copyright owner.

Applications for the copyright owner's permission to reproduce any part of this publication should be made, giving details of the proposed use, to the following address: The Company Secretary, Baxi Heating UK Limited, The Wyvern Business Park, Stanier Way, Derby, DE21 6BF.

Warning: Any person who does any unauthorised act in relation to a copyright work may be liable to criminal prosecution and civil claims for damages.

Because our policy is one of constant development and improvement, details may vary slightly from those given in this publication

Safety First.

This fire is CE Approved and designed to meet the appropriate British Standards and Safety Marks.



Quality and Excellence.

This fire is manufactured to the highest standards of quality and excellence and are manufactured under a BS EN ISO 9001 quality system accepted by the British Standards Institute.



The Highest Standards

The manufacturer is a member of SBGI and HHIC (Heating and Hot water Industry Council) that work to ensure high standards of safety, quality and performance.



Careful Installation

This fire must be installed by a competent GAS SAFE REGISTER engineer (GAS SAFE REGISTER or CORGI engineer outside of UK) in accordance with our installer guide and should not be fitted directly on to a carpet or floor of combustible material.



INSTALLER GUIDE

FOR OWNER GUIDE SEE PAGES 35 TO 42

INSTALLER GUIDE

CONTENTS

<u>Section</u>	<u>Heading</u>	<u>Page</u>
	INSTALLER GUIDE	4 - 34
	OWNER GUIDE	35 - 42
1.	SAFETY AND UNPACKING	7
2.	APPLIANCE DATA AND EFFICIENCY	8
	2.1 General information.	8
	2.2 Efficiency.	8
3.	GENERAL INSTALLATION REQUIREMENTS	9
	3.1 Regulations, Standards and Law.	9
	3.2 Ventilation requirements.	10
	3.3 The Atmosphere sensing device (ASD).	10
	3.4 Fireguard requirements.	10
	3.5 Room considerations.	10
	3.6 Chimney preparation.	11
	3.7 Fireplace preparation.	11
	3.8 The hearth.	12
	3.9 Fireplace clearances.	12
	3.10 Installation options.	13
	3.10.1 Conventional fireplace and hearth.	13
	3.10.2 Metal flue box and hearth.	14
	3.10.3 Precast concrete or clay flue block system and hearth.	15
	3.11 Flues.	15
	3.12 Propane fires.	16
4.	PACK CONTENTS	16
5.	FIREPLACE CHECK	18
	5.1 Soundness for appliance attachment.	18
	5.2 Fireplace flue pull.	18
6.	IGNITION CHECK	19
7.	GAS SUPPLY CONNECTION	19
8.	PREPARING APPLIANCE FOR INSTALLATION	20
9.	CONVECTION BOX INSTALLATION	22
	9.1 Method 1 - Front fixing to fireplace surround.	22
	9.2 Method 2 - Cable retention and floor fixing.	22
	9.3 Sealing floor front - all installations.	25

Continued on next page

INSTALLER GUIDE

CONTENTS (Continued)

<u>Section</u>	<u>Heading</u>	<u>Page</u>
10.	BURNER & SUPPLY PIPE INSTALLATION	25
10.1	Burner and supply pipe installation.	25
10.2	Preliminary burner checks.	25
10.2.1	Lighting the fire.	25
10.2.2	Operating the burner.	25
10.2.3	Checking the inlet pressure.	26
11.	CERAMIC WALLS INSTALLATION	26
12.	FITTING THE CERAMIC FUEL EFFECT	27
13.	FITTING THE FASCIA	28
14.	FULL OPERATING CHECKS	28
14.1	Spillage check.	28
14.2	Flame supervision and spillage monitoring system.	29
15.	FINAL REVIEW	30
16.	SERVICING & PARTS REPLACEMENT	31
16.1	Checking the aeration setting of the burner.	32
16.2	To remove the fascia.	32
16.3	To remove the complete burner unit.	32
16.4	To remove the pilot unit.	32
16.5	To remove the gas valve.	33
16.6	To remove the piezo generator.	33
16.7	To grease the gas valve.	33
16.8	To replace the burner.	34
16.9	To remove the main burner injector.	34

INSTALLER GUIDE

1. SAFETY AND UNPACKING

Installer

Before continuing any further with the installation of this appliance please read the following guide to manual handling.

- The lifting weight of the heat engine and convection box is 6.39kg.
- One person should be sufficient to lift the heat engine and convection box. If for any reason this weight is considered too heavy then obtain assistance.
- When lifting always keep your back straight. Bend your legs and not your back.
- Avoid twisting at the waist. It is better to reposition your feet.
- Avoid upper body/top heavy bending. Do not lean forward or sideways whilst handling the heat engine and convection box.
- Always grip with the palm of the hand. Do not use the tips of fingers for support.
- Always keep the heat engine as close to the body as possible. This will minimise the cantilever action.
- Use gloves to provide additional grip.
- Always use assistance if required.

This product uses fuel effect pieces and burner compartment walls containing Refractory Ceramic Fibres (RCF), which are man-made vitreous silicate fibres. Excessive exposure to these materials may cause irritation to eyes, skin and respiratory tract. Consequently, it is important to take care when handling these articles to ensure that the release of dust is kept to a minimum. To ensure that the release of fibres from these RCF articles is kept to a minimum, during installation and servicing we recommend that you use a HEPA filtered vacuum to remove any dust and soot accumulated in and around the fire before and after working on the fire. When replacing these articles we recommend that the replaced items are not broken up, but are sealed within a heavy duty polythene bag, clearly labelled as RCF waste. RCF waste is classed as a stable, non-reactive hazardous waste and may be disposed at a landfill licenced to accept such waste. Protective clothing is not required when handling these articles, but we recommend the use of suitable gloves to prevent irritation. We also recommend you follow the normal hygiene rules of not smoking, eating or drinking in the work area and always wash your hands before eating or drinking.

This appliance does not contain any component manufactured from asbestos or asbestos related products.

INSTALLER GUIDE

2. APPLIANCE DATA AND EFFICIENCY

2.1 General information.

Gas	Natural (G20)	Propane (G31) *
Inlet Pressure	20mbar	37mbar
Input - Max. (Gross)	6.85kW (23,400 Btu/h)	6.7kW (22,860 Btu/h)
Input - Min. (Gross)	2.3kW (7,850 Btu/h)	4.0kW (13,650 Btu/h)
Burner Test Pressure (Cold)	20.0 ± 1.0 mbar (8.0 ± 0.4in w.g.)	37.0 ± 1.0 mbar (14.85 ± 0.4in w.g.)
Gas Connection	8mm pipe	8mm pipe
Burner Injector	Cat 82 - 074	Size 132
Pilot & Atmosphere Sensing Device	Copreci Ref. O.D.S 21500/166	Copreci Ref. O.D.S 21500/166 Fitted with RBM 180 -02 injector
Ignition	Integral Piezo Spark	Integral Piezo Spark
Aeration	Factory set.	Non-adjustable

*When converted using kit 0595211.

The appliance information label is located on a 'pivot' plate at the base of the fire. This can be seen by pulling on the raised tab.

2.2 Efficiency.

The efficiency of this appliance has been measured as specified in BS 7977 - 1 and the result is as below:

<u>Model</u>	<u>Efficiency % (Gross)</u>
951	58
951 when converted to LPG.	61

The gross calorific value of the fuel has been used for this efficiency calculation. The test data from which it has been calculated has been certified by Advantica Certification services (0087). The efficiency value may be used in the UK Government's Standard Assessment Procedure (SAP) for energy rating of dwellings.

INSTALLER GUIDE

The conversion of **net** efficiency to **gross** was achieved by multiplying the net efficiency by the following conversion factor from Table E3 of SAP 2005, rounding down to the nearest whole number.

Gas	Conversion factor from net to gross efficiency
Natural Gas	0.901
LPG	0.921

3. GENERAL INSTALLATION REQUIREMENTS

3.1 Regulations, Standards and Law.

The installation must be in accordance with these instructions.

For the user's protection, in the United Kingdom it is the law that all gas appliances are installed by competent persons in accordance with the current edition of the Gas Safety (Installation and Use) Regulations. Failure to install the appliance correctly could lead to prosecution. GAS SAFE REGISTER and CORGI require their members to work to recognised standards.

In the United Kingdom the installation must also be in accordance with:

All the relevant parts of local regulations.

All relevant codes of practice.

The relevant parts of the current editions of the following British Standards:-

BS EN 1856 Part 1 - Chimneys - Requirements for metal chimneys.

BS 715 - Specification for metal flue boxes for gas-fired appliances not exceeding 20kW.

BS EN 1858 - Chimneys - Components - Concrete flue blocks.

BS EN 1806 - Chimneys - Clay / ceramic flue blocks.

BS EN 1856 Part 1 - Chimneys - Requirements for metal chimneys.

BS 5440 Part 1 - Installation of flues.

BS 5440 Part 2 - Installation and maintenance of flues and ventilation for gas appliances of rated input not exceeding 70 kW net (1st, 2nd and 3rd family gases).

BS 6461 Part 1 - Masonry chimney & flues - Installation

BS 1251 - Fireplace components

BS 5871 Part 2 - Installation - Inset LFE gas fires

BS 6891 - Gas pipework installation

- In England and Wales, the current edition of the Building Regulations issued by the Department of the Environment and the Welsh Office.
- In Scotland, the current edition of the Building Standards (Scotland) Regulations issued by the Scottish Executive.
- In Northern Ireland, the current edition of the Building regulations (Northern Ireland) issued by the Department of the Environment for Northern Ireland.
- In the republic of Ireland the installation must be carried out by a competent person

INSTALLER GUIDE

and also conform to the relevant parts of:

- a) The current edition of IS 813 “Domestic Gas Installations”
- b) All relevant national and local rules in force.

Where no specific instructions are given, reference should be made to the relevant British Standard Code of Practice.

3.2 Ventilation requirements.

Normal adventitious ventilation is usually sufficient to satisfy the ventilation requirements of this appliance. In GB reference should be made to BS 5871 Part 2 and in IE reference should be made to the current edition of IS 813 “Domestic Gas Installations” which makes clear the conditions that must be met to demonstrate that sufficient ventilation is available.

3.3 The Atmosphere sensing device (ASD).

The appliance is fitted with an A.S.D (Atmosphere sensing device). If the appliance closes down after a period of operation for no apparent reason, the consumer should be informed to stop using the appliance until the installation and appliance have been thoroughly checked. The A.S.D will shut the appliance down if an unacceptable amount of harmful products of combustion accumulate. Under no circumstances should the A.S.D be altered or bypassed in any way. Only a genuine manufacturers replacement part should be fitted. The individual A.S.D components are not replaceable.

3.4 Fireguard requirements.

A fireguard complying with BS 8423 should be fitted for the protection of young children, the elderly, the infirm and pet animals.

3.5 Room considerations.

3.5.1 This appliance must not be installed in any room that contains a bath or shower or where steam is regularly present.

3.5.2 An extractor fan may only be used in the same room as this appliance, or in any area from which ventilation for the appliance is taken, if it does not affect the safe performance of the appliance. Note the spillage test requirements detailed further on in this manual. If the fan is likely to affect the appliance, the appliance must not be installed unless the fan is permanently disconnected.

3.5.3 Note that soft wall coverings (e.g. embossed vinyl, etc.) are easily affected by heat. They may scorch or become discoloured when close to a heating appliance. Please bear this in mind when installing.

INSTALLER GUIDE

3.6 Chimney preparation.

3.6.1 If the appliance is intended to be installed to a chimney that was previously used for solid fuel, the flue must be swept clean prior to installation.

All flues should be inspected for soundness and freedom from blockages.

3.6.2 Any chimney damper or restrictor should be removed. If removal is not possible, they must be secured in the open position.

3.6.3 The flue must not be used for any other appliance or application.

3.7 Fireplace preparation.

3.7.1 If the fireplace opening is an underfloor draught type, it must be sealed to stop any draughts.

3.7.2 The surface of the hearth must be sufficiently flat to enable the bottom of the front surround and the bottom front cover to be aligned horizontally. Any excessive unevenness (uneven tiles, Cotswold stone, etc.) should be rectified.

3.7.3 The front face of the fireplace should be reasonably flat over the area covered by the convection box top and side flange seals to ensure good sealing. These faces should be made good if necessary. The fireplace floor should be reasonably flat to ensure that a good seal with the convection box can be made.

3.7.4 If the appliance is to be fitted against a wall with combustible cladding, the cladding must be removed from the area shown in figure 1.

3.7.5 If the fireplace opening is greater than the acceptable dimensions given in this guide, do not use the back of a fire surround or marble to reduce the opening.

This may cause cracking of the surround back or marble.

3.7.6 The appliance must not stand on combustible materials or carpets.

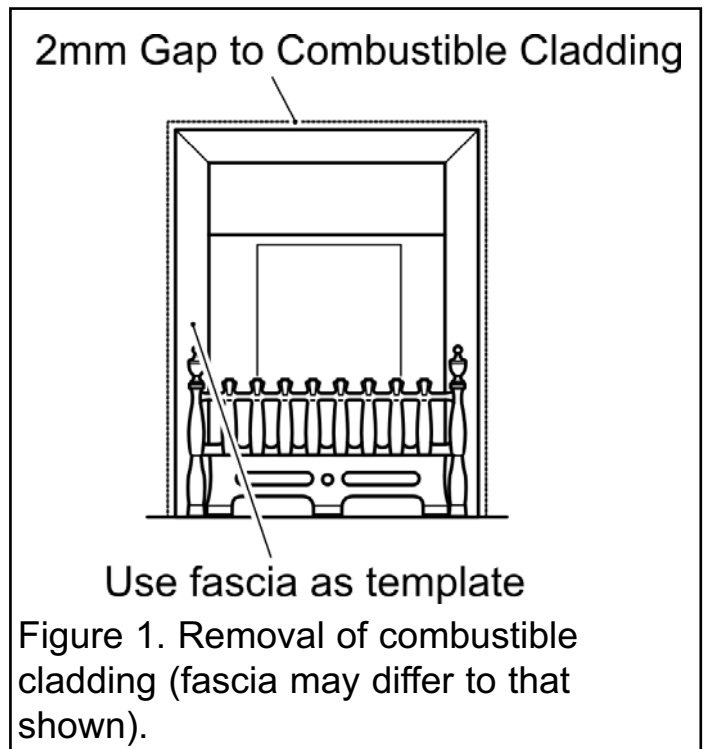

INSTALLER GUIDE

3.8 The hearth.

The appliance must be mounted behind a non-combustible hearth unless the conditions of section 3.10.1.1 are met (N.B. conglomerate marble hearths are considered as non-combustible). The appliance can be fitted to a minimum class “O” 150°C surround. The hearth material must be at least 12mm thick. The periphery of the hearth (or fender) should be at least 50mm above floor level to discourage the placing of carpets or rugs over it (See figure 3).

3.9 Fireplace clearances.

3.9.1 The minimum height from the top surface of the hearth to the underside of any shelf made from wood or other combustible materials is shown below: -

- For a shelf up to 150mm deep
Minimum height = 760mm.
- For a shelf deeper than 150mm
Minimum height = 760mm + 12.5mm for every 25mm depth over 150mm.
(See Figure 2).

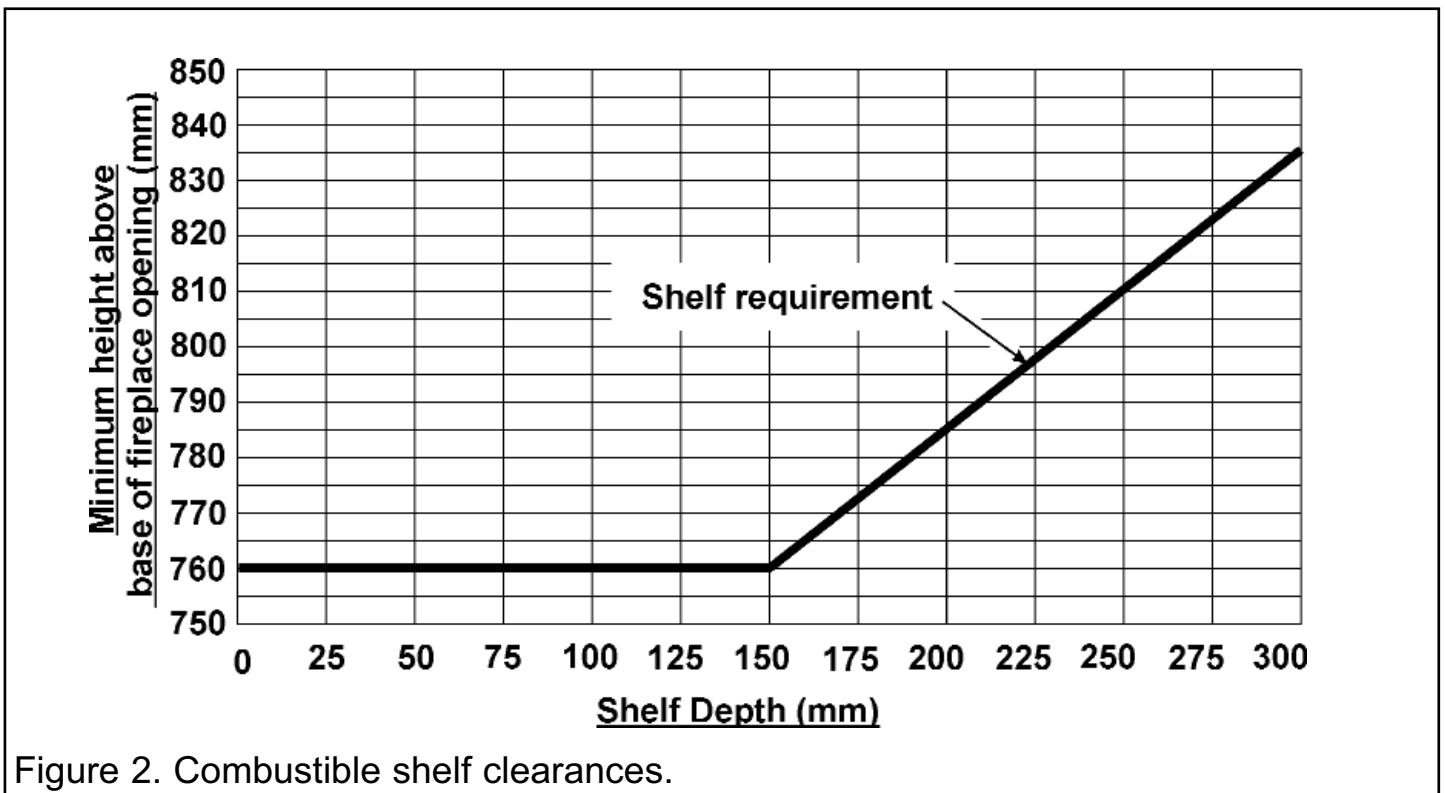

Figure 2. Combustible shelf clearances.

3.9.2 The minimum allowable distance from the outside of the fascia to a corner wall having combustible material or any other combustible surface which projects beyond the front of the appliance is 100mm.

A 10mm access clearance from a non-combustible surface is necessary at both sides.

INSTALLER GUIDE

3.10 Installation options.

In the United Kingdom, as supplied, the appliance can be installed in the following situations: -

3.10.1 Conventional fireplace and hearth.

To a fireplace complete with surround and hearth as shown in figure 3 and complying with BS1251 after removal of the fireback and sufficient material behind the fireback for a debris catchment space. The required fireplace, hearth, debris catchment area and clearance dimensions are shown in figure 4.

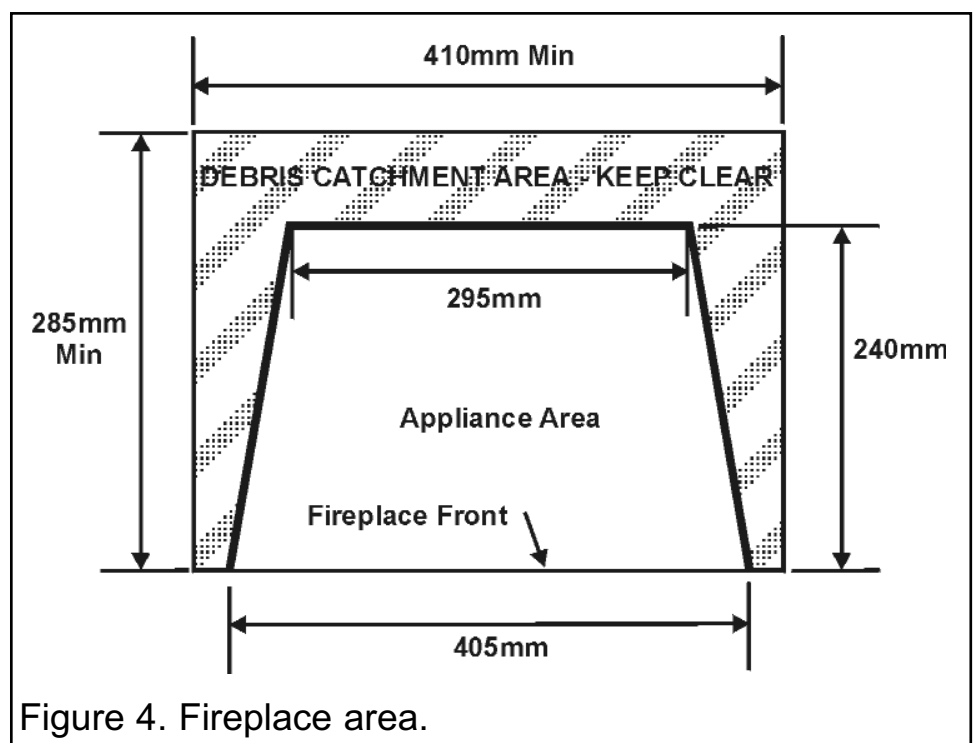
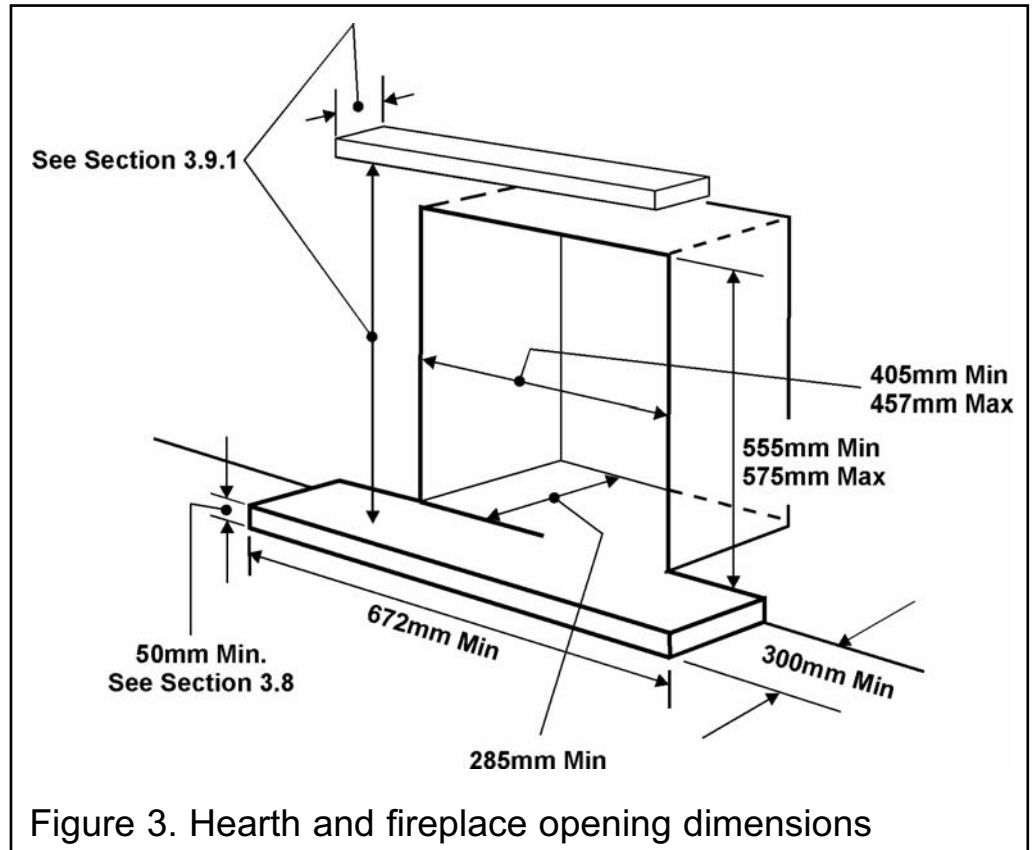

INSTALLER GUIDE

3.10.1.1 'Hole-in-the-wall' installations

It is recommended that a hearth should be installed as in figure 3.

- If fitting a fascia that has a firefront designed to sit on a hearth, a reduced depth hearth is recommended. It is recommended that the reduced hearth has a depth from the fixing plane of the fire of 100mm minimum. This is necessary to support the lower front casting. The heat engine must be installed so that distance from the base of the fireplace opening in the wall to the finished floor level shall be at least 100mm. Where there is no floor covering or carpet, and the floor is of a type that is likely to be covered in such a way in the future, then the distance from the base of the fireplace opening in the wall to the floor level should be increased to at least 175mm.
- If fitting a fascia that does not have a separate firefront and a hearth is not fitted, the heat engine must be installed so that distance from the base of the fireplace opening in the wall to the finished floor level shall be at least 100mm. Where there is no floor covering or carpet and the floor is of a type that is likely to be covered in such a way in the future then the distance from the base of the fireplace opening in the wall to the floor level should be increased to at least 175mm.
- To protect from the risk of burns and ignition of clothing a tactile separator shall be used. The hearth detailed in section 3.8 meets the requirements for a tactile separator. If this is not used then a 672mm long fender, kerb, horizontal bar, or other barrier, being fixed not less than 50mm above floor level and positioned 300mm in front of the fixing plane of the fire will meet the requirement.

3.10.2 Metal flue box and hearth.

To a fireplace incorporating a metal flue box complying with the constructional requirements of the current edition of BS715. The dimensions of the flue box must conform to those shown in figure 5.

The top of the metal flue box must be covered with a 100mm layer of mineral wool or equivalent insulation.

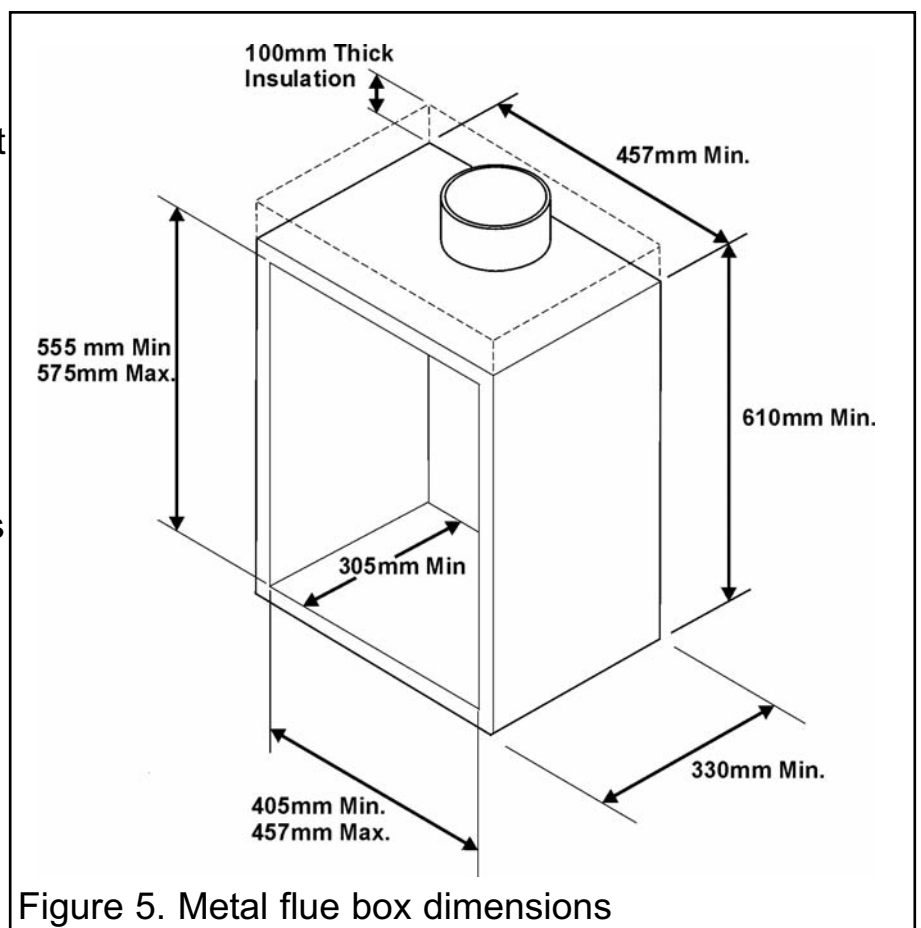

Figure 5. Metal flue box dimensions

INSTALLER GUIDE

Important Note: Where the flue box has a base sheet that is single wall (i.e. a single metal sheet) the flue box must be mounted on a non-combustible hearth. The hearth material must be at least 12mm thick.

3.10.3 Precast concrete or clay flue block system and hearth.

To a precast concrete or clay flue block system conforming to BS1289 with dimensions as in figure 6. The current versions of BS1289 and BS EN 1806 recommend that there should be an air space or insulation between the flue blocks and the plaster because heat transfer may cause cracking on directly plastered flues. However, generally this appliance is suitable for installations under all circumstances unless there is a history of cracking problems.

Remember that faults such as cracking may be caused by poorly built and restrictive flues, e.g. mortar extrusions, too many bends, flue heights below three metres, restrictive terminations etc.

3.11 Flues.

1. Suitable flues and minimum flue sizes are as follows: -

It should be noted that, as with many appliances, sharp bends or horizontal runs in metal flues at the top of the system can be a cause of problems in these types of installation.

- 225mm x 225mm conventional brick flue.

- 175mm diameter lined brick or stone flue.

- 200mm diameter factory made insulated flue manufactured to BS4543.

- 175mm diameter flue pipe. See BS6461 Part 1 for suitable materials.

- Single wall, twin wall or flexible flue liner with a minimum diameter of 125mm. The materials to be used are stainless steel or aluminium as specified in BS715. The liner must be sealed to the surrounding area above the fireplace opening and to the top of the chimney. An approved terminal must be fitted.

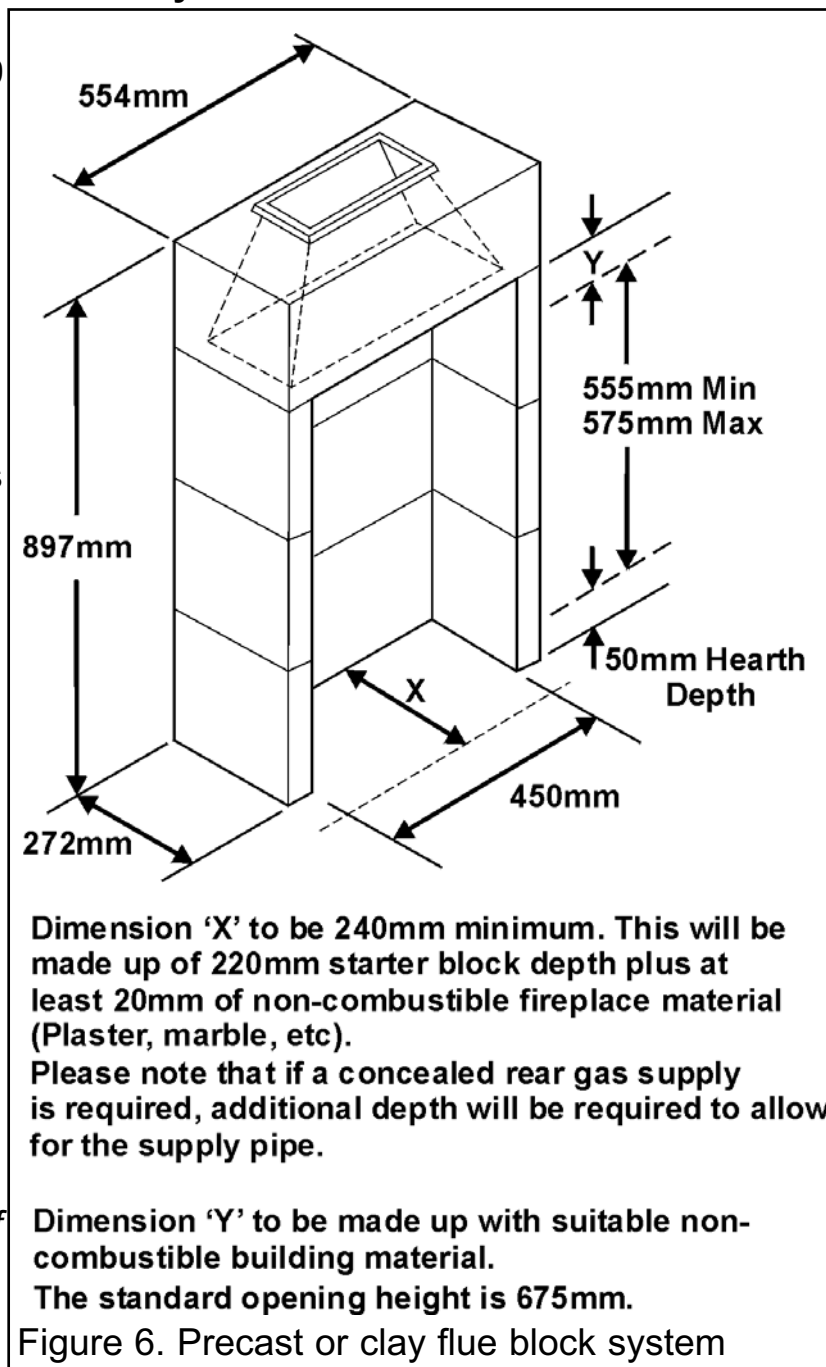

INSTALLER GUIDE

● A properly constructed precast concrete or clay flue system conforming to BS1289 or BS EN 1806. This system is only suitable if the conditions stated in section 3.10.3 are met.

2. The flue must conform to BS 5440: Part 1 in design and installation.

The flue, measured from the bottom of the fireplace opening to the bottom of the terminal, shall be not less than 3m in actual vertical height. When calculated in accordance with BS 5440: Part 1 Annex A, the minimum **equivalent** height of the flue shall be 2.0m of 125mm dia. flue pipe.

3. The flue must not be used for any other appliance or application.

4. Proprietary terminals must comply with BS 715 or BS 1289. Any terminal or termination must be positioned in accordance with BS 5440 Part 1 to ensure that the products of combustion can be safely dispersed into the outside atmosphere. Where the appliance is connected to an unlined brick chimney it is generally unnecessary for the chimney pot to be replaced or for a terminal to be fitted unless the flue has a diameter smaller than 170mm.

3.12 Propane fires.

Propane gas appliances must not be installed in a room that is built entirely below ground level (See BS 5871 Part 2).

4. PACK CONTENTS

Carefully remove all the contents. Check that all the listed parts are present and in good condition.

Appliance contains: (See figure 7)

- 1 Burner and convection box unit.
- 1 Nut and olive for 8mm inlet pipe.
- 1 Inlet 'T' connector and pressure test point.
- 1 Flue restrictor.
- 3 Screws (For fitting the flue restrictor).
- 1 Rear ceramic wall support bracket
- 2 Screws (For fitting the rear ceramic wall support bracket).
- 1 Ceramic back wall.
- 1 Pair of ceramic side walls.
- 2 Small "U" seals for the convection box side flanges.
- 1 Strip of floor sealing tape.
- 6 Fibre wall plugs.
- 4 Woodscrews.
- 2 Fire retaining cables.
- 2 Cable clamps.

INSTALLER GUIDE

- 4 Eyebolts.
- 1 Rubber grommet.
- 1 Smoke match tube.
- 1 Length of self adhesive foam seal.
- 1 Canopy shield (This may be supplied with either the fascia or the convection box).
- 3 Screws (For fitting the canopy shield).
- 2 Machine screws (For fascia securing).
- 2 Washers (For fascia securing)
- 1 Ceramic fuel effect (Not shown).
- 1 Literature pack (Not shown).

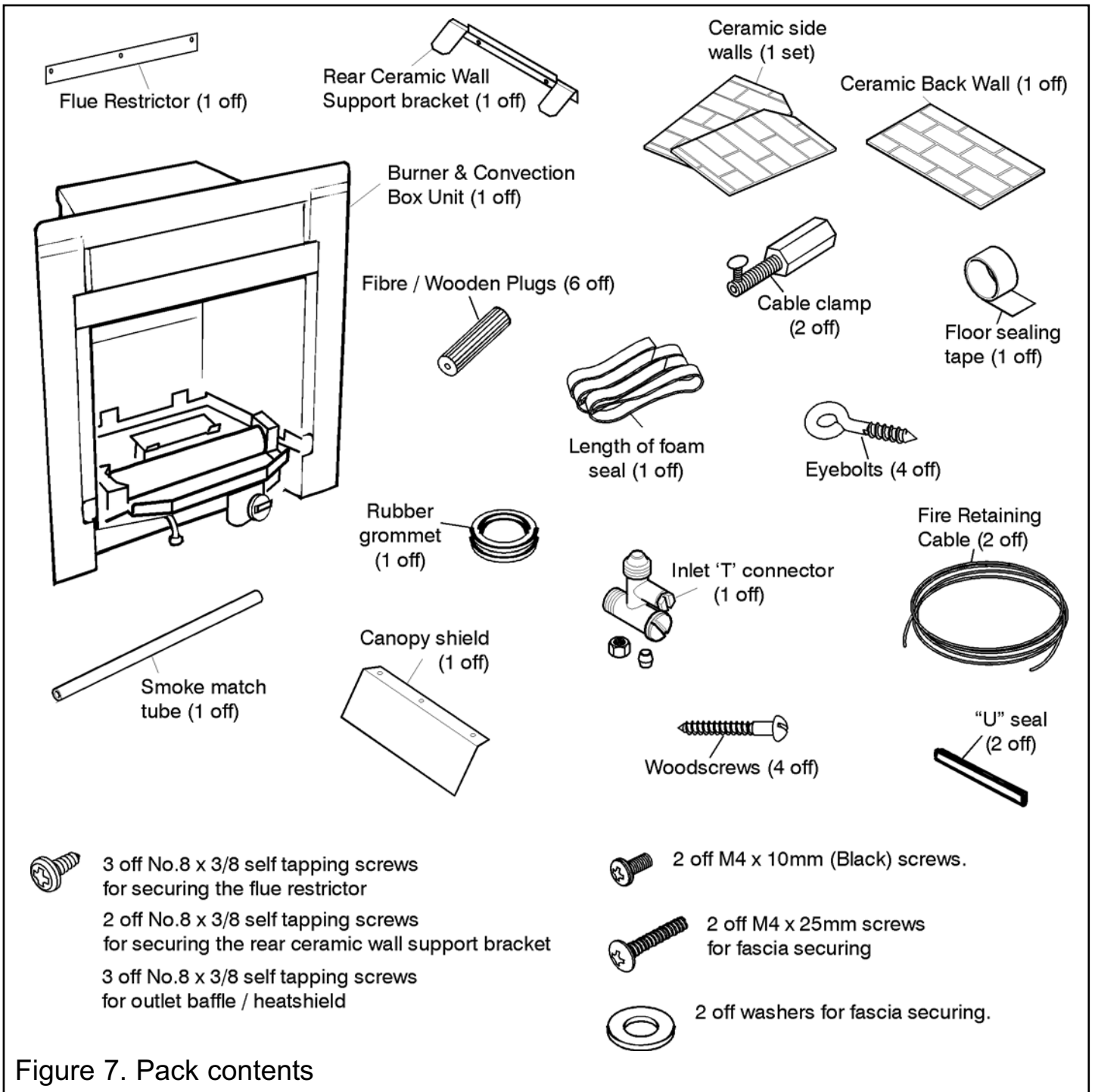

Figure 7. Pack contents

5.1 Soundness for appliance attachment.

Two primary methods of retaining the appliance are provided: -

- 1) By fixing to the fireplace front surround.
- 2) Using concealed tension cables fixed to the rear of the fireplace opening together with secondary fixing to the fireplace floor.

The methods are detailed in section 9 of this manual. Before selecting the retention method, consult with the customer. Method 2 is provided for instances where drilling holes in the front surface of the fireplace surround is unacceptable to the customer or otherwise impractical. *N.B. It is unwise to attempt to drill into marble without the proper tools and equipment.*

If method 1 is chosen, make sure that the front surround area is sound enough to take the fibre wall plugs and woodscrews. If necessary, make sound with suitable cement.

If method 2 is chosen, make sure that the areas at the back and towards the centre of the fireplace floor are sound enough to take the eyebolts and screws. If these areas have deteriorated due to prolonged use, they should be made sound with suitable cement.

5.2 Fireplace flue pull.

Close all doors and windows in the room in which the appliance is to be installed. After confirming with a match that smoke is drawn into the flue, light a 13 gram smoke pellet and check that there is a definite flow through the flue. Verify outside that the smoke exits from one terminal only and that the termination is suitable. Observe, where possible, upstairs rooms and loft spaces for signs of escaping smoke indicating a defective flue. If there is not a definite flow warm the flue for a few minutes and repeat the smoke pellet test. If there is still no definite flow the flue may need remedial work – **Do not fit the appliance until there is a definite flow through the flue.**

INSTALLER GUIDE

6. IGNITION CHECK

Before attempting to install, it is worth checking that the ignition system performs satisfactorily.

Set the control knob to the off position.

Depress the control knob and rotate it anticlockwise to the pilot ignition position. A 'click' will be heard as the integral piezo operates. A spark should be seen between the electrode and pilot tip. If there is no spark check the following: -

- Ensure that the electrode lead is connected to the terminal at the base of the electrode.
- If the above is correct, check for damage to the electrode lead.

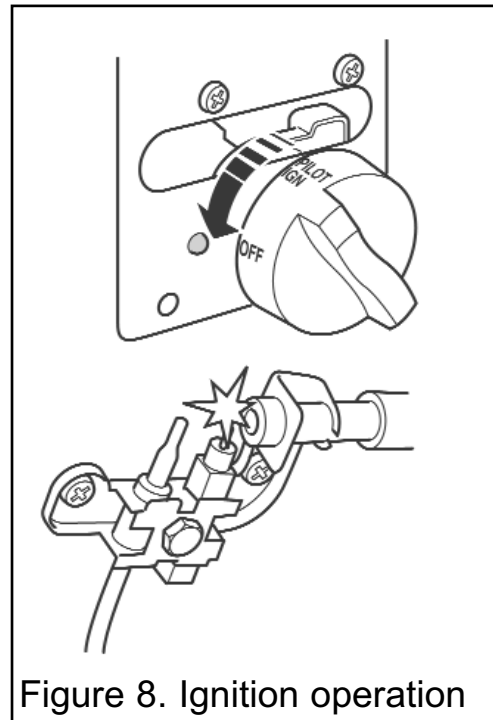

Figure 8. Ignition operation

7. GAS SUPPLY CONNECTION

A nut and olive are provided for an 8mm pipe inlet connection to the 'T' connector at the bottom front of the appliance. The 'T' connector can be rotated to allow a connection from any direction and includes a valve for isolating the gas supply and a pressure test point.

The supply pipe must be rigid material. Flexible pipe must not be used.

Concealed supply pipe connection

If a concealed connection from inside the fireplace is required then, **before the appliance is fitted into the fireplace** it will be necessary to extend the supply line so that it will project through the hole in the back of the convection box and run to the 'T' connector at the front. The pipe run from the supply line up to the rear opening in the convection box must be kept away from the area which will be taken by the convection box when it is installed (See figure 4).

Note that the centre of the appliance inlet 'T' connector is 25mm above the fireplace floor. The inlet 'T' connector should be fitted to the supply pipe at this stage.

INSTALLER GUIDE

8. PREPARING APPLIANCE FOR INSTALLATION

1. Detach the burner unit from the convection box by removing two screws (See figure 9). Lift the burner unit clear.
2. Fit the two “U” section seals to the bottom edges of the convection box side flanges (See figure 10).
3. **It is important that the grommet supplied in the loose parts pack is fitted to the hole in the rear of the convection box.**

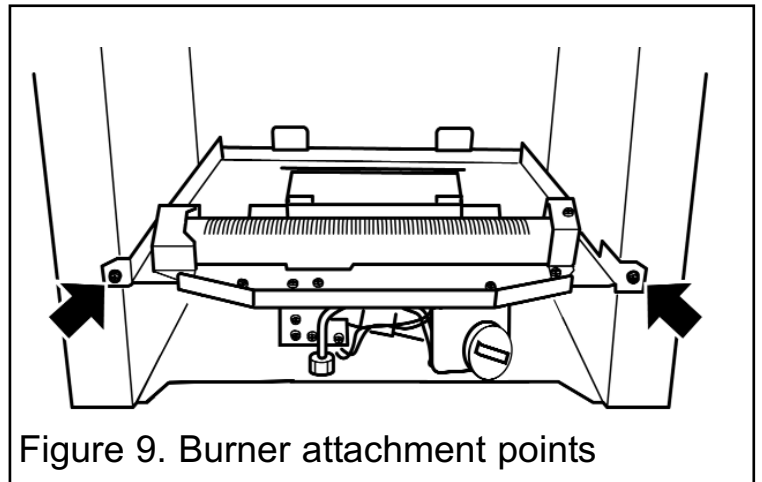

4. For concealed connection only:

Pierce the grommet to allow the pipe to pass through it. The grommet should envelop the pipe. If the hole is larger than the pipe, seal it with tape. **Do not pierce the grommet unless the supply pipe is to pass through it.**

5. The heat engine or fascia will have a canopy shield supplied with it. Fit this to the convected air outlet of the appliance using the three self tapping screws supplied. The design of the canopy shield may differ from that shown (See figure 11).

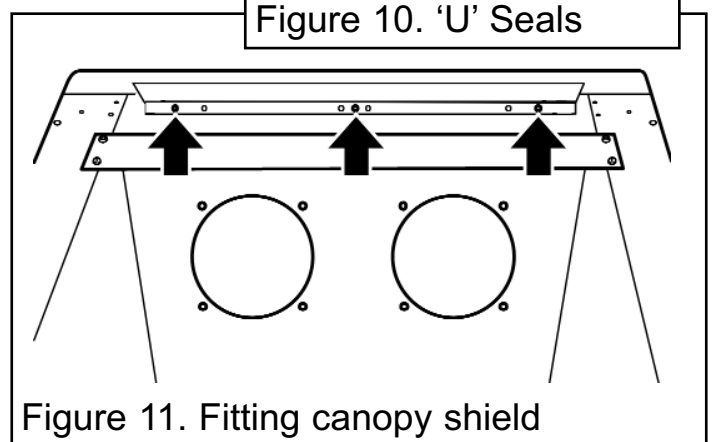
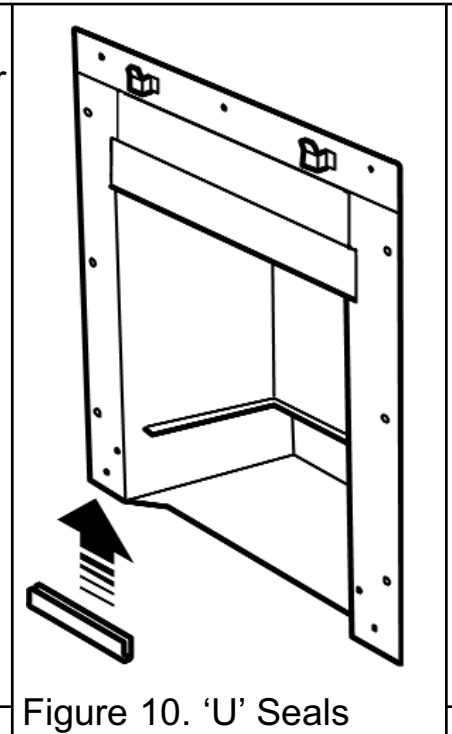

INSTALLER GUIDE

6. This appliance is supplied with a rear ceramic support bracket. Fit this using two screws supplied (See figure 12).

7. This appliance is supplied with a flue restrictor for use where the flue draught is excessive. The restrictor must NOT be fitted where a precast flue or a flue liner is used. For all other installations the restrictor should be fitted. There may however, be certain exceptional circumstances where fitting the restrictor causes the fire to fail the spillage test. In such cases the restrictor will have to be removed. After removal conduct the spillage check again.

The restrictor is packed loose with the appliance and is fixed with three screws (See figure 13).

8. There is a length of self adhesive foam seal supplied with the fire. This will need to be fitted to the outer rear edges of the side and top flanges of the convection box. Cut a 485mm length of foam seal. Be careful not to stretch the seal when measuring. Remove the protective backing from the foam seal and fit this to the rear of the top flange (See figure 14). Cut two 580mm lengths. Fit these to the rear outer edges of the side flanges. Ensure that there is no gap between the foam seals where they meet at the top flange (See figure 14).

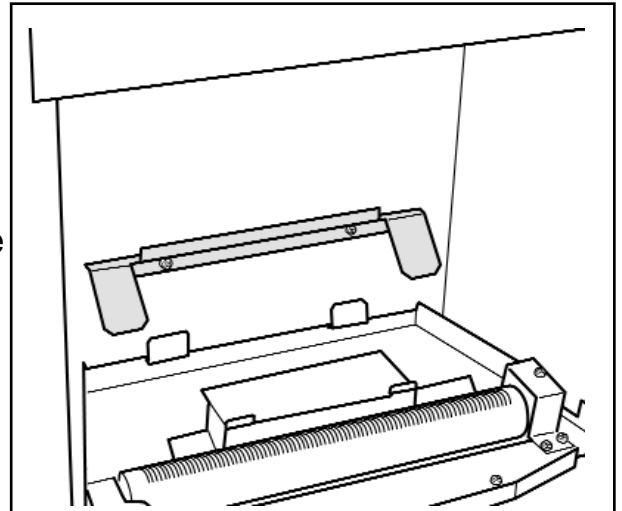

Figure 12. Fitting the rear ceramic support.

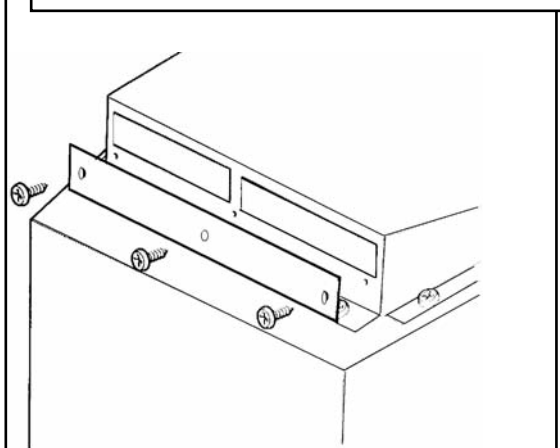

Figure 13. Flue restrictor

The foam seal should touch at this point. Ensure that there is no gap between the seals.

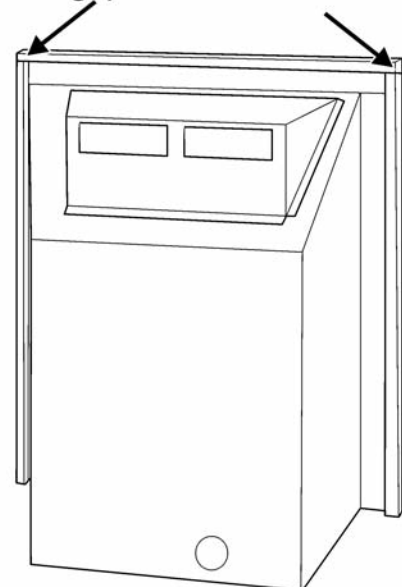

Figure 14. Fitting the foam seal

INSTALLER GUIDE

9. CONVECTION BOX INSTALLATION

9.1 Method 1 - Front fixing to fireplace surround.

1. Make sure that the fireplace front surround area is sound enough to take the fibre plugs and woodscrews. If necessary, make sound with suitable cement.
2. Place the convection box centrally in the fireplace in the position in which it is to be permanently installed. If a concealed connection is being used, insert the convection box into the fireplace feeding the supply pipe through the pierced hole in the rear grommet.
3. Mark the fireplace front surround through the four fixing holes in the side flanges of the convection box (See figure 15).
4. Remove the convection box. Drill four holes in the fireplace front surround at the marked positions using a suitably sized drill bit for the wall plugs supplied.
5. Insert a fibre plug into each hole.
6. Place the convection box back in position in the fireplace.
7. Fit a woodscrew through each hole in the convection box flanges and tighten to seal the box to the fireplace surround.

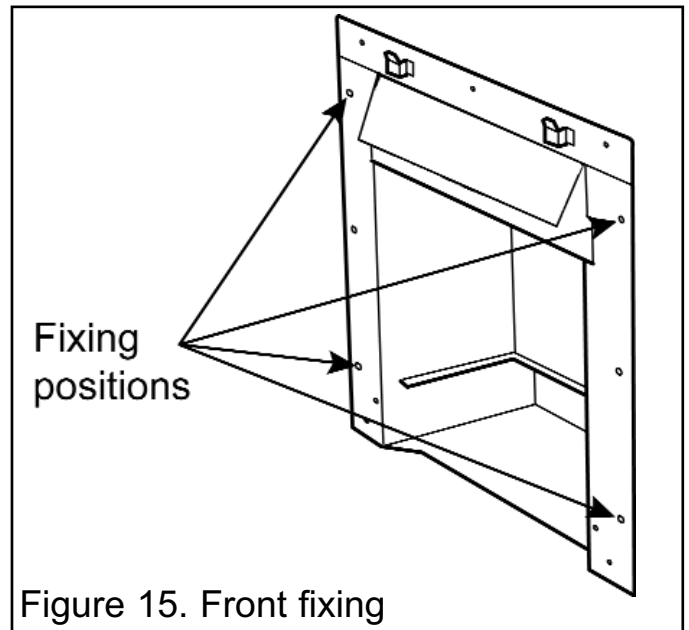

9.2 Method 2 - Cable retention and floor fixing.

1. Make sure that the relevant areas at the fireplace back or floor are sound enough to take the eyebolts and screws. If these areas have deteriorated due to prolonged use they should be made sound with suitable cement.
2. Drill four holes in the rear wall of the fireplace for the eyebolt plugs. The holes should be drilled within the range of positions shown in figure 16 using a suitably sized drill bit for the wall plugs supplied. The holes should be equidistant each side of the centre line of the fireplace to ensure that the appliance finishes centrally in the opening when tension is applied to the cables.
3. Insert a fibre plug into each hole. Use the fibre plugs supplied with this appliance - **Never use plastic plugs instead of the fibre plugs supplied.** Screw the eyebolts into the plugs. Make sure that the bolts are secure.
4. Place the convection box unit close to the fireplace but allow sufficient access into the fireplace opening so that the cables can be threaded through the eyebolts and returned through the back of the convection box. If a concealed connection is being used, insert the convection box into the fireplace feeding the supply pipe through the pierced hole in the rear grommet.

INSTALLER GUIDE

5. The convection box has two holes at each side of the convected air opening. Insert one end of each cable (one cable each side) from the back through the lower of the two holes and return the end through the upper of the holes (See figure 17). Give the cables a pull so that they grip against the convection box flanges.

6. Thread the cables through the eyebolts. Return the cables through the holes near the bottom of the convection box back panel (See figure 18) **(For precast or clay block flue systems return the cables through the slotted holes in the side of the convection box).**

7. Place the convection box fully back into the fireplace opening so that it is sealed against the fireplace front surround.

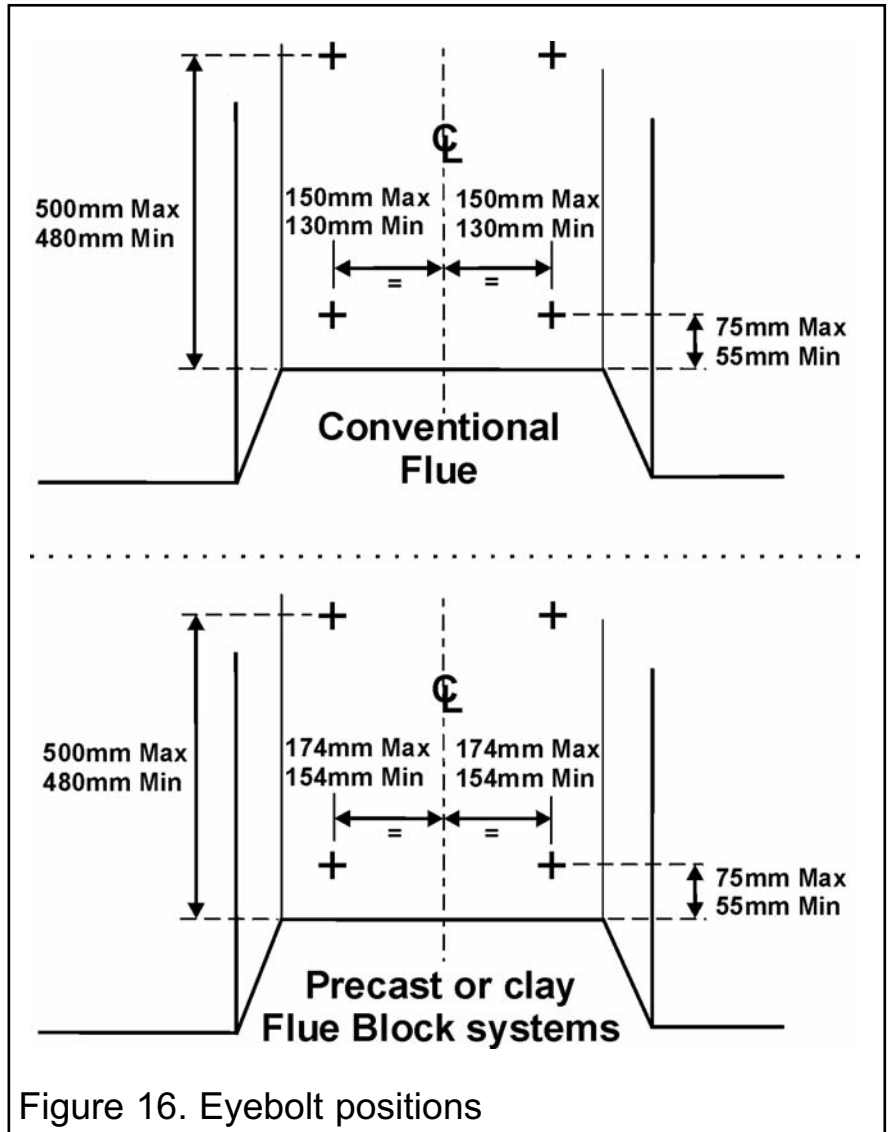

Figure 16. Eyebolt positions

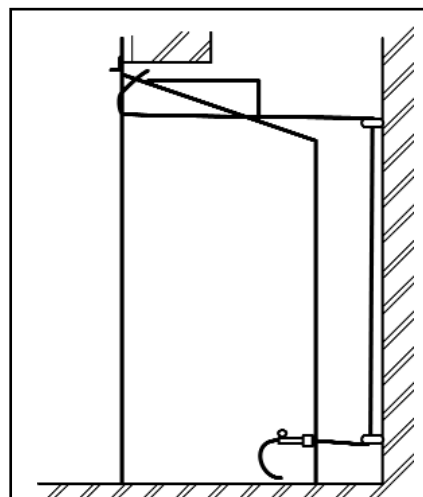

Figure 18. Cable route

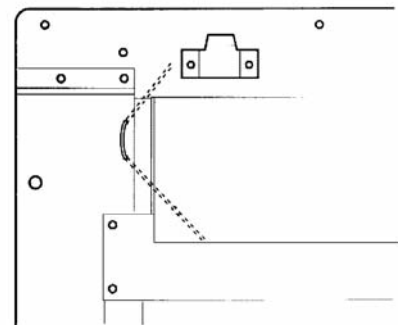

Figure 17. Upper cable retention

INSTALLER GUIDE

8. Drill a hole into the fireplace floor through each of the two holes in the base of the convection box using a suitably sized masonry drill bit for the fibre plugs supplied (See figure 19).

9. Insert a fibre plug into each hole. Use the fibre plugs supplied with this appliance - **Never use plastic plugs instead of the fibre plugs supplied.** Fit a woodscrew in each plug and tighten.

Always screw the base into position before applying tension to the cables. This will ensure a tight seal between the top of the convection box and wall.

10. Fit a cable retainer over the bottom end of each cable.

11. Pull each cable taut. Push the cable retainers hard up against the back panel. The end of the cable adjuster will pass into the hole. Tighten the screws in the retainers so that they clamp the cables in position. Apply tension to the cables by turning the hexagonal adjusters by hand (See figure 20).

12. Inspect the installation of the convection box against the fireplace surround. If the convection box is aligned squarely and the sealing is satisfactory, fully tighten the cable retainers.

13. If the convection box is not correctly aligned, release the tension on the cables by slackening the screws and turning the hexagonal adjusters fully anticlockwise. The convection box should then automatically realign itself. Pull each cable taut again and push the cable retainers back against the back panel. Again, tighten the screws in the retainers and apply tension to the cables by turning the hexagonal adjusters clockwise as far as possible.

14. Feed the free length of the cables into the gap between the inner and outer back panels so that they are available to allow easy removal and refitting of the appliance during subsequent service calls. **Do not cut off the free lengths of cable.** On precast flue installations feed the cables into the small holes at the base of the side panels (See figure 20)

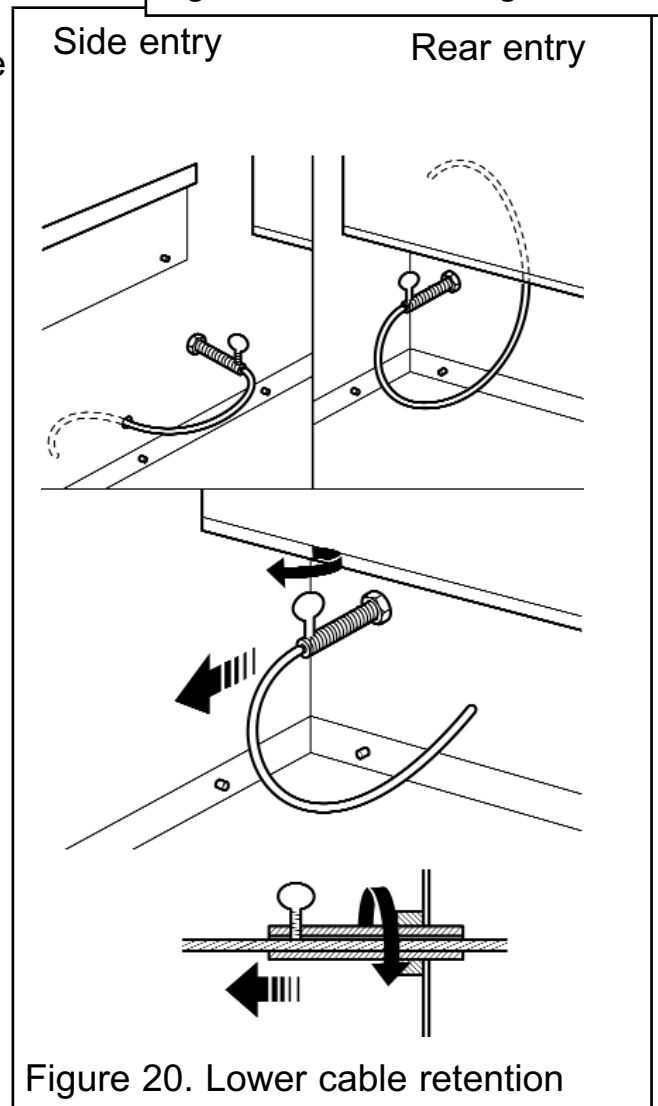
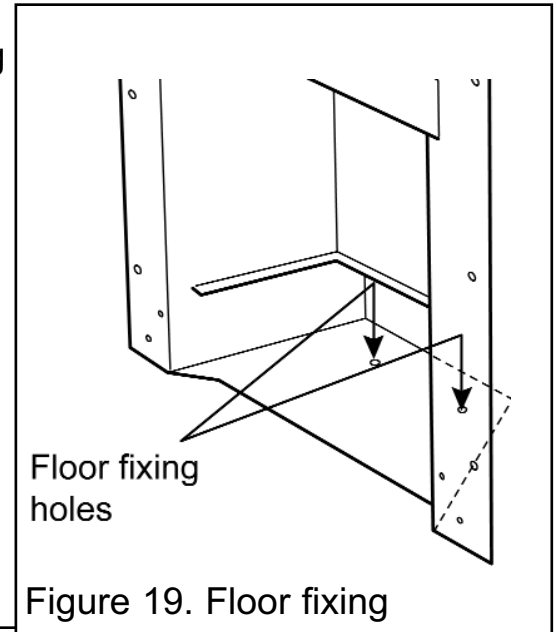

INSTALLER GUIDE

9.3 Sealing floor front - all installations.

Using the floor sealing tape supplied, seal the bottom of the convection box to the fireplace and hearth floor (See figure 21).

Make sure that the whole length of the front edge of the convection box is fully sealed.

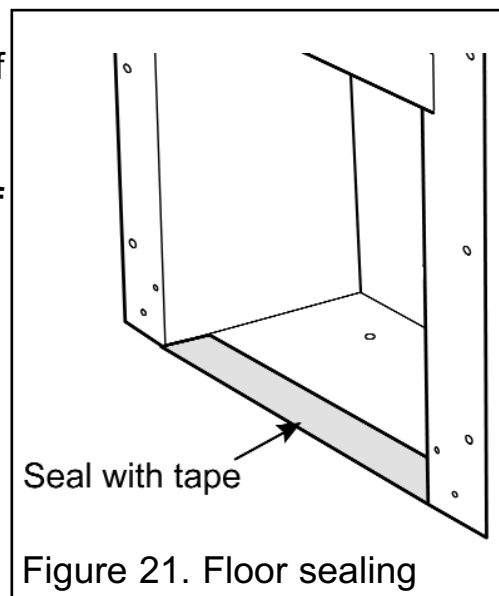

10. BURNER & SUPPLY PIPE INSTALLATION

10.1 Burner and supply pipe installation.

1. Refit the burner unit to the convection box with two screws.
2. Connect the supply line to the appliance.
3. Turn on the gas supply and pressure check the installation pipework for gas soundness. In the United Kingdom (GB) check in accordance with the current edition of BS 6891. In the Republic of Ireland check in accordance with the current edition of IS 813 "Domestic Gas Installations".

10.2 Preliminary burner checks.

Some burner operations can be checked at this stage. Checking now will mean that less disassembly will be required if any problems are found. **A full check should still be made, however, after final installation.**

10.2.1 Lighting the fire.

If closed, open the isolating inlet 'T' connector. Depress the control knob and slowly rotate it anticlockwise to the pilot ignition position. A 'click' will be heard as the integral piezo operates. A spark should be seen between the electrode and pilot tip. Turn the control knob clockwise to the 'Off' position. Repeat this operation until a flame appears at the pilot. There may be a delay before the pilot lights due to air being purged from the system. When a flame appears at the pilot keep the control knob depressed and hold the pilot ignition position for five seconds. When the control knob is released the pilot flame should remain lit.

10.2.2 Operating the burner.

When the pilot burner is operating properly, gradually turn the control knob anti-clockwise to 'HIGH' (Depress the knob slightly to get past the pilot ignition position). The main burner should now light. Depress the control knob slightly to release from the 'HIGH' position and turn back (clockwise) to 'LOW'. While turning, the burner

INSTALLER GUIDE

flames should gradually become lower but remain alight. Depress the control knob slightly to release from the 'LOW' position and turn back (clockwise) to the Pilot ignition position. The main burner should extinguish but the pilot should remain alight. Depress the control knob slightly and turn back (clockwise) to turn OFF.

This will extinguish the pilot.

10.2.3 Checking the inlet pressure.

The appliance is pre-set to give the correct heat input at the inlet pressure shown in section 2 of this manual. No adjustment is necessary.

1. Check the inlet pressure by fitting a pressure gauge at the test point. The test point is on the inlet 'T' connector (See figure 22). Check the pressure with the appliance alight and set at maximum output.
2. After checking, turn off the appliance. Remove the pressure gauge and replace the test point sealing screw.
3. Test around the sealing screw for gas soundness with a suitable leak detection fluid.

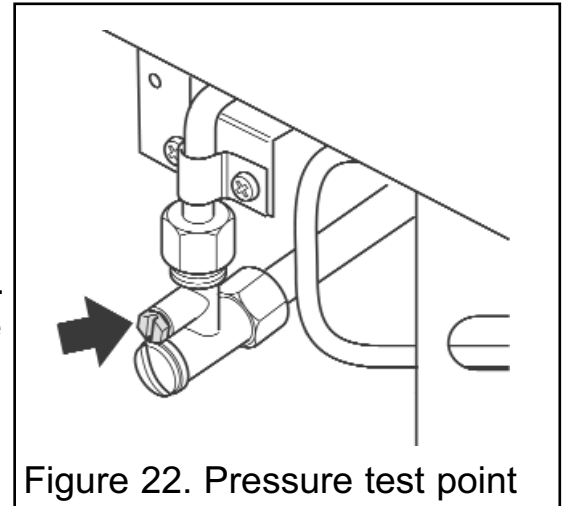

Figure 22. Pressure test point

11. CERAMIC WALLS INSTALLATION

1. Fit the ceramic rear wall inside the "L" bracket on the back face of the burner compartment. Push the ceramic wall flat against the back face of the burner compartment (See figure 23).

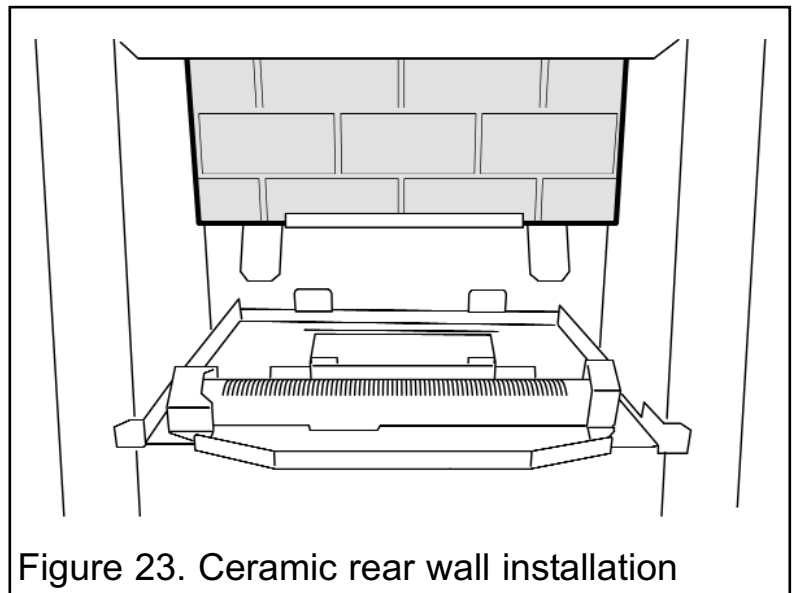

Figure 23. Ceramic rear wall installation

INSTALLER GUIDE

2. Remove four screws from the spillage plate sides (See figure 24).
3. Remove the spillage plate by lifting it forward.
4. Fit the ceramic side walls against the side faces of the burner compartment. The bottom edges of the walls should rest in the ledges at the sides of the firebox. Slide them in from the front and ensure that they touch the rear wall. The friction between the side walls and the rear wall should hold the side walls in position (See figure 24).
5. Re-fit the spillage plate. Be careful not to damage the edges of the side walls. The spillage plate will hold the side walls in place.

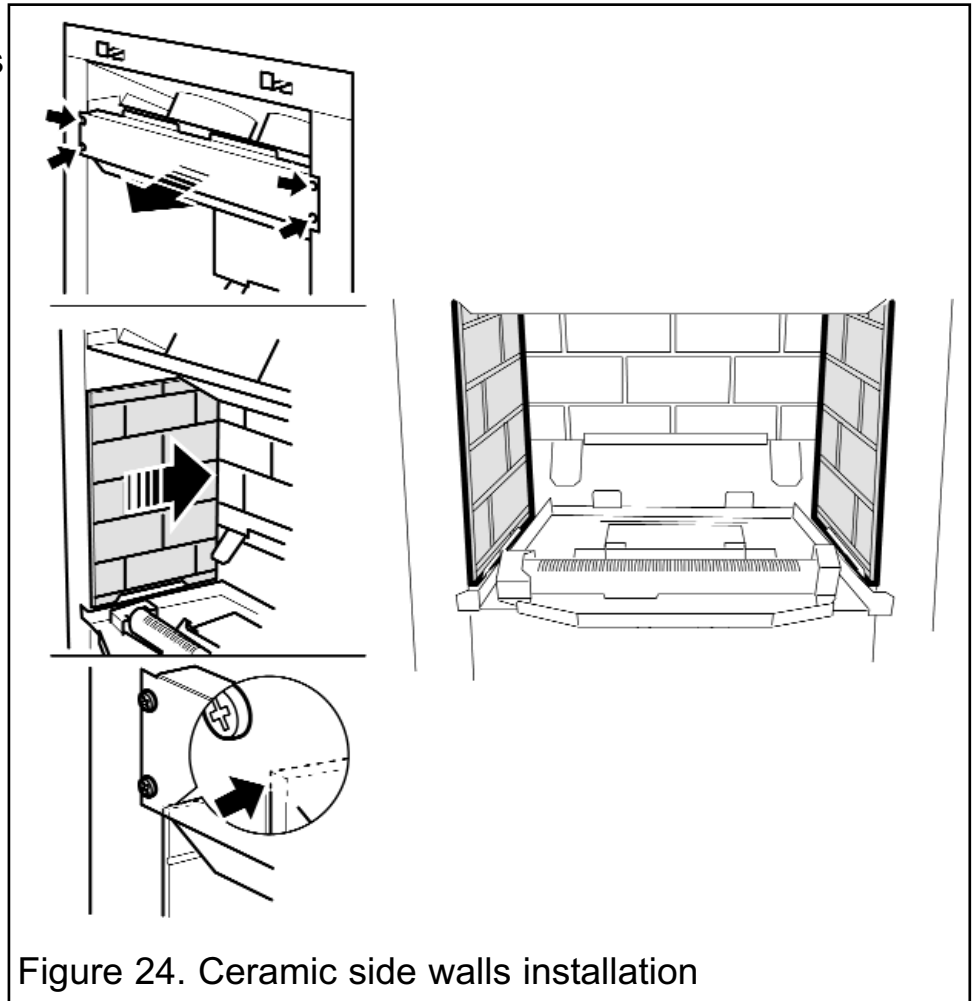

Figure 24. Ceramic side walls installation

12. FITTING THE CERAMIC FUEL EFFECT

The fitting guide for the ceramic fuel effect is supplied with the ceramic fuel effect. It is important that the fitting guide for the ceramic fuel effect be placed inside or attached to this guide and handed to the customer following completion of the 'final review' section.

INSTALLER GUIDE

13. FITTING THE FASCIA

The fitting guide for the fascia is supplied with the fascia. Fit the fascia in accordance to the fascia fitting guide. There is a self adhesive control position label supplied with this appliance. Where applicable this should be adhered to the fascia as shown in the fascia fitting guide.

14. FULL OPERATING CHECKS

A spillage check must be made before leaving the installed appliance with the customer. Make this with all the ceramic fuel effect pieces and complete fascia in position.

14.1 Spillage check.

1. Close all doors and windows in the room containing the appliance.
2. Light the appliance and set the control to the maximum burning position.
3. Leave the appliance on for five minutes.
4. The smoke match should be placed horizontally into the convection box at the right hand side. There is a notch in the black cross member. Insert the tube so that the neck of its flared end is 5mm passed and in contact the cross member (See figure 25).

The installation is satisfactory if the smoke is drawn into the appliance. If the smoke is not drawn into the appliance leave the appliance alight at the maximum setting for a further ten minutes and then repeat the test. If the smoke is still not drawn into the appliance inspect the sealing to the fireplace surround. If the sealing is satisfactory but the appliance is installed with the flue restrictor (See section 8 point 7) remove the restrictor, reseal the appliance and retest. If smoke is still not drawn into the appliance

disconnect the appliance and seek expert advice.

5. If the above test is satisfactory open all internal connecting doors, hatches, etc. in the room. Keep all doors and windows that open to the outside of the building closed. Recheck for spillage as above. If an extractor fan is installed in the same room as the appliance or a connecting room, check that spillage does not occur with the fan operating and all doors and other openings between the fan and the appliance open.

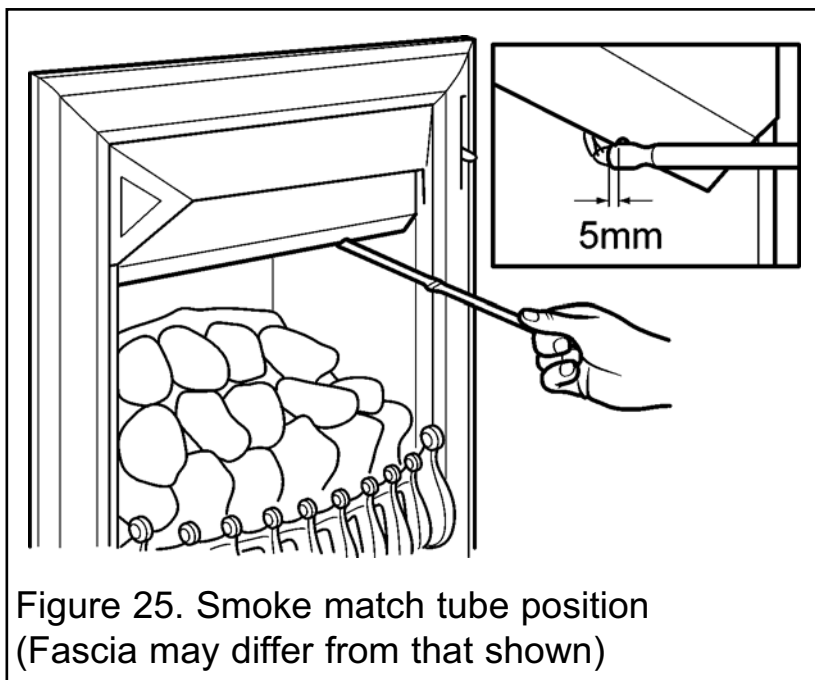

INSTALLER GUIDE

If the smoke is drawn into the appliance, continue with the installation. If the test is not satisfactory **disconnect the appliance and advise the customer of the cause of failure.**

14.2 Flame supervision and spillage monitoring system.

The pilot unit incorporates a system that will automatically shut off the gas supply if the pilot flame goes out or if there is insufficient oxygen due to spillage or lack of ventilation.

Check that the system operates properly as follows:

- Light the appliance. Set at the "HIGH" position and leave for one minute.
- Turn back to "OFF" to extinguish the pilot. **Note the time when the pilot goes out.** Listen for a snap sound at the gas tap. **Note the time when the sound is heard.** An electromagnetic valve shutting off the gas supply through the tap causes this sound. The valve is located in the body of the tap. The valve should operate **within 60 seconds of the pilot going out.** If the valve does not operate within this time limit do not allow the appliance to be used until the fault has been corrected. **This monitoring system must not be adjusted, bypassed or put out of operation.**

This monitoring system, or any of its parts, must only be exchanged using authorised parts.

INSTALLER GUIDE

15. FINAL REVIEW

1. If a gap is visible between the inner sides of the fascia and the ceramic side walls, gently slide the walls forward.
2. Visually inspect the appliance. Clean off any marks incurred during installation.
3. Advise the customer how to operate the appliance. Point out that lighting instruction details are on the metal plate attached at the bottom of the appliance. Explain to the customer that the appliance has a flame failure & spillage monitoring system. Point out the explanation of this system shown in the owner guide under "Operating the fire". Advise that if the fire goes out for any reason, wait at least three minutes before relighting. Stress that if the monitoring system repeatedly shuts off the fire, the appliance should be switched off and a specialist should be consulted.
4. Advise the customer that they should read their owner guide before operating the fire and always follow the advice in the section headed "Cleaning your fire".
5. **Stress that no extra ceramic fuel effect pieces must be added over and above those supplied with the appliance and that any replacements must only be the authorised spares. Warn that ignoring this advice could cause incomplete clearance of the products of combustion with consequent health hazards.**
6. Advise the customer that the appliance will operate to its maximum potential if the flue is primed during the first 20 – 30 minutes of use. To do this, simply slide the control to its highest setting. This will also burn off any carbon deposits that may have formed during previous use.
If using the appliance for long periods it is beneficial to change between settings. This will also help to remove any carbon deposits that may form during use.
7. Recommend that the appliance should be serviced by a competent person at least annually.
8. If the appliance is in premises in the United Kingdom occupied by a tenant, point out that by law a landlord must have any gas appliance, flue and pipework which is situated in a tenant's premises checked for safety at least every 12 months.
9. Advise that the fire may give off a slight odour while new. This is quite normal and it will disappear after a short period of use.
10. **Inform the customer that the Serial number for the appliance is located on the data label located behind the firefront and underneath the burner module.**
11. Hand the literature pack with this guide to the customer.

16. SERVICING & PARTS REPLACEMENT

- Always turn off the gas supply and allow the fire to cool completely before commencing any servicing (The appliance inlet 'T' connector incorporates an isolating valve).
 - It is recommended that, at least once a year, the appliance is disconnected and the fireplace opening checked and cleared of any debris.
 - This product uses fuel effect pieces and burner compartment walls containing Refractory Ceramic Fibres (RCF), which are man-made vitreous silicate fibres. Excessive exposure to these materials may cause irritation to eyes, skin and respiratory tract. Consequently, it is important to take care when handling these articles to ensure that the release of dust is kept to a minimum. To ensure that the release of fibres from these RCF articles is kept to a minimum, during installation and servicing we recommend that you use a HEPA filtered vacuum to remove any dust and soot accumulated in and around the fire before and after working on the fire. When replacing these articles we recommend that the replaced items are not broken up, but are sealed within a heavy duty polythene bag, clearly labelled as RCF waste. RCF waste is classed as a stable, non-reactive hazardous waste and may be disposed at a landfill licenced to accept such waste. Protective clothing is not required when handling these articles, but we recommend the use of suitable gloves to prevent irritation. We also recommend you follow the normal hygiene rules of not smoking, eating or drinking in the work area and always wash your hands before eating or drinking.
 - This appliance does not contain any component manufactured from asbestos or asbestos related products.
-
- Check that the appliance is clean and that soot or debris is not blocking the gaps between the ceramic fuel effect pieces causing an imperfect flame.
 - Check that soot or debris is not impairing the electrode spark or pilot burner.
 - Check that soot or debris is not blocking any of the slots in the main burner.
 - After servicing, make sure that the ceramic walls are replaced correctly as described in this guide and the ceramic fuel effect pieces are replaced correctly as described in the installer and owner guide supplied with the ceramic fuel effect. The ceramic fuel effect guide may have been placed inside or attached to this guide.
 - **Always test for gas soundness and spillage after servicing the appliance.**

INSTALLER GUIDE

16.1 Checking the aeration setting of the burner.

1. The aeration shutter is factory set and should not require adjustment. If the shutter is not as shown in figure 26 and requires adjustment, loosen the two aeration shutter screws, slide the aeration shutter to the position shown in figure 26 and tighten the fixing screws.

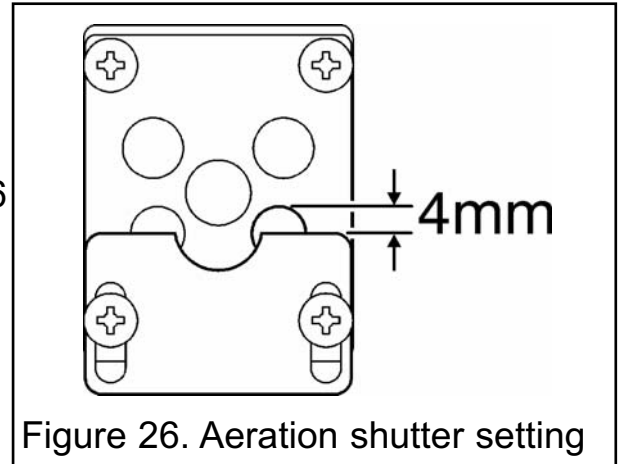

Figure 26. Aeration shutter setting

16.2 To remove the fascia.

1. The installer and owner guide for the fascia is supplied with the fascia. This guide should have been placed inside or attached to this guide.

16.3 To remove the complete burner unit.

1. Remove the firefront and place in a safe position.
2. Remove the fascia (See section 16.2)
3. Remove the ceramic fuel effect. *The installer and owner guide for the ceramic fuel effect is supplied with the fascia and should have been placed inside or attached to this guide. It is important that the ceramic fuel effect guide is followed when fitting the ceramic fuel effect.*
4. Close the valve in the inlet 'T' connector .
5. Disconnect the appliance from the inlet 'T' connector.
6. Remove the two burner securing screws (See figure 27).
7. Lift the burner clear of the convection box.
8. Replace in the reverse order.

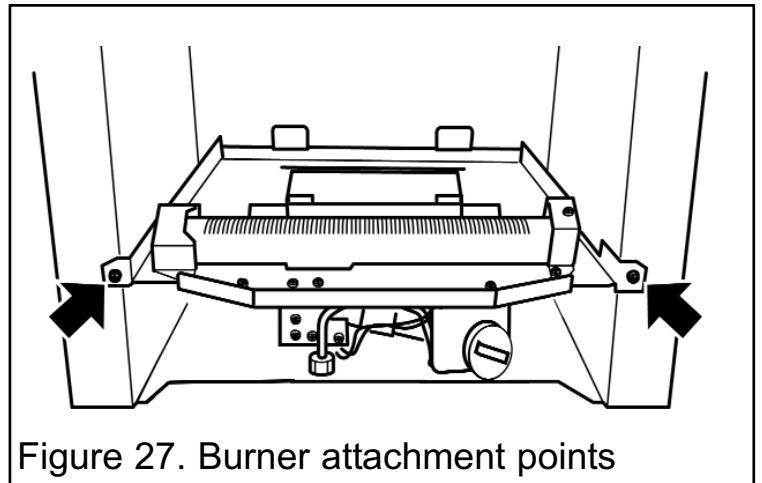

Figure 27. Burner attachment points

16.4 To remove the pilot unit.

1. Remove the complete burner unit (See section 16.3).
2. Detach the pilot pipe from the pilot unit.
3. Detach the thermocouple from the gas valve.
4. Detach the electrode lead from the underside of the electrode tab.
5. Remove the two screws securing the pilot unit (See figure 28).
6. Refit in the reverse order.

Note: *The pilot unit is an atmosphere sensing device. It must be replaced as a whole assembly. Its individual components are not separately replaceable.*

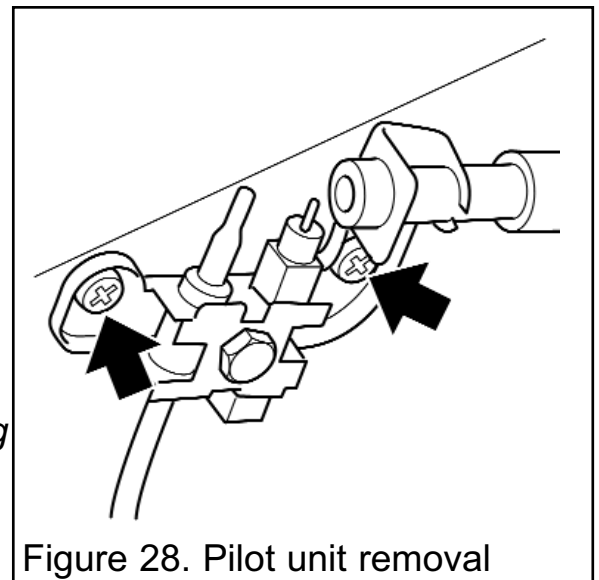

Figure 28. Pilot unit removal

INSTALLER GUIDE

16.5 To remove the gas valve.

(See figure 29).

1. Remove the complete burner unit (See section 16.3).
2. If lying the burner on its back, ensure that the work surface is suitably protected. This will avoid damage to the work surface. Turn the burner unit upside down. Detach the thermocouple from the tap.
3. Detach the pilot pipe from the tap.
4. Detach the inlet pipe.
5. Detach the injector pipe.
6. Detach the electrode lead from the base of the electrode.
7. Remove the control knob by pulling forward.
8. Remove the thermocouple by unscrewing the thermocouple nut at the gas valve.
9. Remove the hexagonal nut securing the gas valve to the mounting bracket.
10. Remove the gas valve
11. Refit in the reverse order.

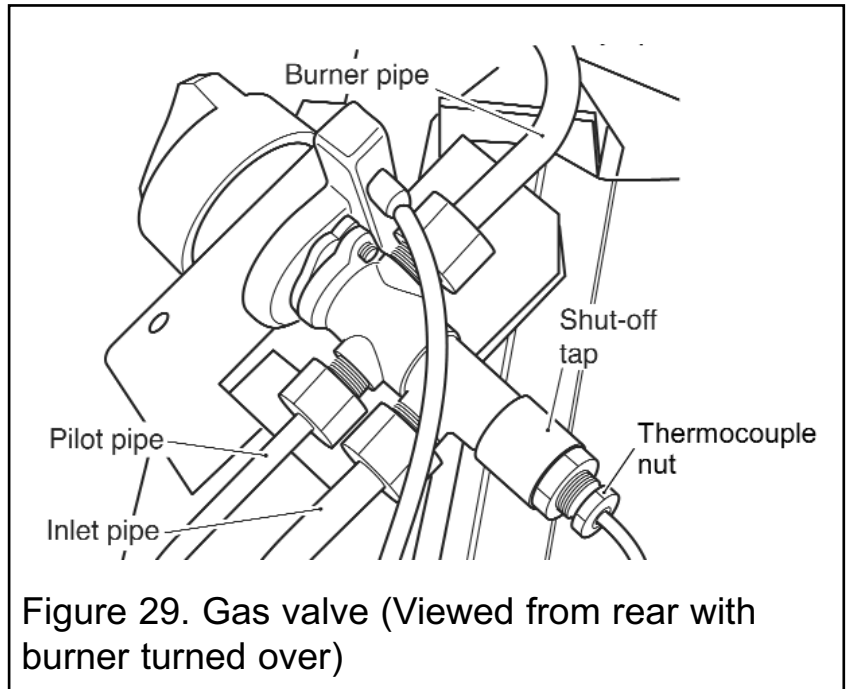

Figure 29. Gas valve (Viewed from rear with burner turned over)

16.6 To remove the piezo generator.

1. Remove the gas valve as in section 16.5.
2. Make sure that the gas valve is in the 'off' position.
3. Remove the circlip holding the piezo unit to the gas valve. Remove the piezo unit.
4. Replace in the reverse order.

16.7 To grease the gas valve.

1. Detach the gas valve and remove the piezo generator as section 16.6 making sure that the gas valve is in the 'off' position.
2. Remove the two screws from the head of the tap. Remove the nutting head and spindle complete with collar and spring.
3. Note the position of the slot in the plug-mark its position on the gas valve body.
4. Remove the plug rotating slightly while pulling.
5. Clean and grease the plug lightly with suitable grease. Do not apply excessive grease. Particularly, make sure that the gas ports in the gas valve are not restricted by grease.
6. Push the plug into the tap body and position the slot in line with the mark previously made on the gas valve body.
7. Reassemble the nutting head and spindle complete with collar and spring making sure that the components are correctly engaged. Check the operation of the tap.
8. Refit the piezo generator.

INSTALLER GUIDE

16.8 To replace the burner.

1. Remove the complete burner unit (See section 16.3).
2. Support the elbow injector and unscrew the injector nut.
3. Remove the two screws from the burner clamping plate (See figure 30)
4. Lift the right hand side of the burner, slide it to the right and lift clear
5. Refit in reverse order.

16.9 To remove the main burner injector.

1. Remove the burner (See section 16.8).
2. Remove the burner clamping screw (See figure 31)
3. Unscrew the injector from the burner
4. Refit in the reverse order.

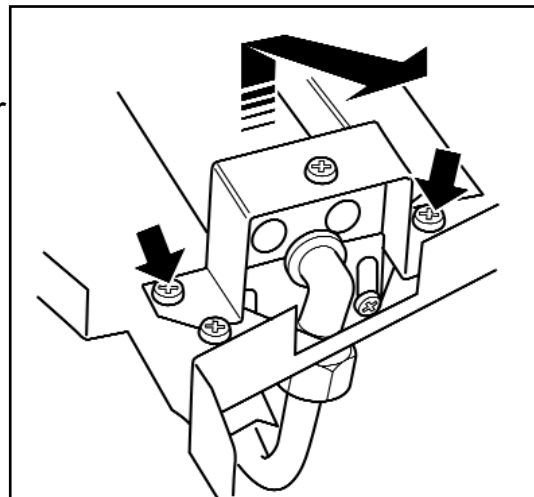

Figure 30. Removal of burner

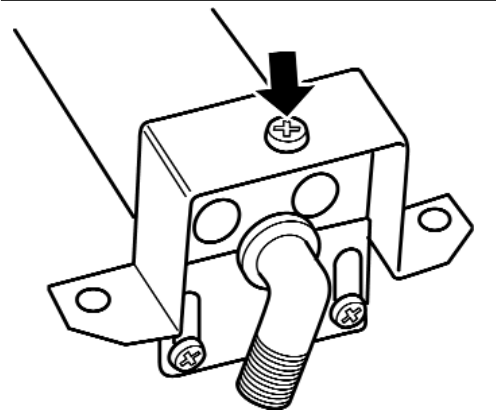

Figure 31. Injector removal

OWNER GUIDE

OWNER GUIDE

LIST OF CONTENTS

<u>Section</u>	<u>Page</u>
SAFETY	37
GAS CONSUMPTION	38
OPERATING YOUR FIRE	39
The Oxysafe flame sensing and flue blockage safety system.	39
To light the fire.	39
Lighting with a taper.	40
CLEANING YOUR FIRE	41
Metal parts.	41
Ceramic fuel effect pieces and burner compartment walls.	41
Burner.	41
CERAMIC FUEL BED REFITTING	42
MAINTENANCE	42
Regular maintenance.	42
Servicing.	42

This gas fire is designed to meet the most stringent quality, performance and safety requirements to provide you with many years' trouble-free service.

This guide aims to improve your understanding and appreciation of your gas fire by providing simple and informative instructions to ensure that you benefit from the excellent performance and features it has to offer.

OWNER GUIDE

SAFETY

IF YOU SMELL GAS

- **DON'T SMOKE.**
- **EXTINGUISH ALL NAKED FLAMES.**
- **DON'T TURN ELECTRICAL SWITCHES ON OR OFF.**
- **TURN OFF THE GAS SUPPLY AT THE METER OR TANK AS APPROPRIATE.**
- **OPEN DOORS AND WINDOWS TO GET RID OF THE GAS.**
- **IMMEDIATELY CALL THE GAS EMERGENCY SERVICE FROM A NEIGHBOURS PHONE - SEE YOUR LOCAL TELEPHONE DIRECTORY.**

Do have the fire installed by a competent person. In the United Kingdom, installation must be in accordance with the latest edition of the Gas Safety (installation & use) Regulations. In the Republic of Ireland, installation must be in accordance with all national and local regulations in force.

Do have the chimney swept prior to installation if it was previously used for solid fuel.

Do have the fire installed in accordance with the installation instructions.

Do allow a minimum clearance of 760 mm from the top of the base of the convector box to the underside of any shelf whether it is made from combustible or non-combustible materials. For a shelf made from wood or other combustible materials deeper than 150mm add 12.5mm to the clearance for every 25mm of additional shelf depth (See figure 1). Please bear this in mind if ever you add a shelf.

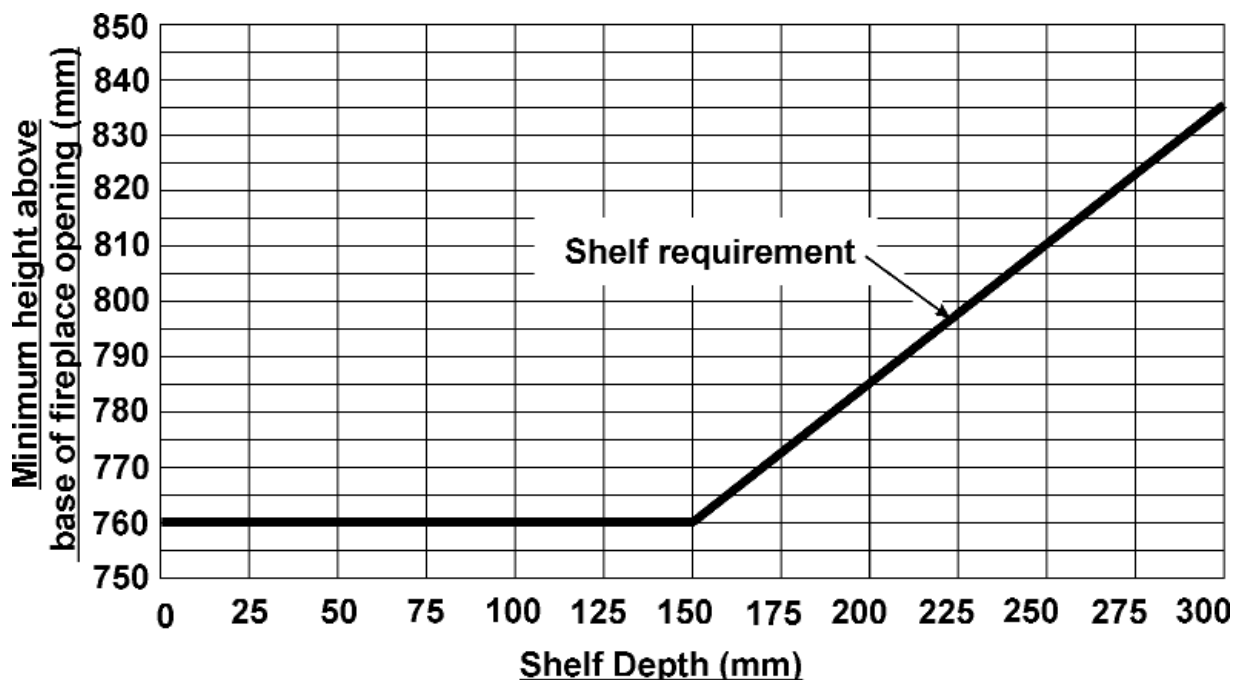

Figure 1. Combustible shelf clearances

OWNER GUIDE

Do provide a suitable guard that complies with BS 8423 for the protection of young children, the elderly, the infirm and pet animals. (Although this fire conforms to all the applicable standards, it is a heating appliance and certain parts of its surface will become hot).

Do wait three minutes before attempting to relight if the fire is switched off or the flames are extinguished for any reason. (Your fire is fitted with a safety device that will automatically shut off the gas supply to the fire if, for any reason, the flames go out).

Do get advice about the suitability of any wall covering near your fire. Soft wall coverings (e.g. embossed vinyl, etc.) which have a raised pattern are easily affected by heat. They may, therefore, scorch or become discoloured when close to a heating appliance. Please bear this in mind whenever you are considering redecorating.

Do provide a minimum side clearance as detailed below:

The minimum allowable distance from the outside of the fascia to a corner wall having combustible material or any other combustible surface which projects beyond the front of the appliance is 100mm.

A 10mm access clearance from a non-combustible surface is necessary at both sides.

Don't hang clothing, towels or any other fabrics over the fire.

Don't add any extra fuel effect pieces above the number stated in the installer and owner guide supplied with the ceramic fuel effect. The installer may have attached it to this guide or placed it inside. Adding extra fuel effect pieces could cause a safety hazard and consequent health hazards.

Don't put paper or any other material on the fire.

Don't place any combustible material (rugs, carpet, plastic tiles, etc.) on the hearth.

Don't attempt to clean or service the fire until it has been switched off and allowed to cool completely.

GAS CONSUMPTION

Model 951

Has a maximum natural gas input of 6.85kW (Gross)

Has a maximum natural gas output of 3.75kW

Has a minimum natural gas input of 2.3kW (Gross)

Has a minimum natural gas output of 1.15kW

Model 951 when converted using kit number 0595211

Has a maximum propane gas input of 6.7kW (Gross)

Has a maximum propane gas output of 3.95kW

Has a minimum propane gas input of 4.0kW (Gross)

Has a minimum propane gas output of 2.35kW

OWNER GUIDE

OPERATING YOUR FIRE

PLEASE NOTE

When operating your fire for the first time, some vapours may be given off which may cause a slight odour and could possibly set off any smoke alarms in the immediate vicinity. These vapours are quite normal with new appliances. They are totally harmless and will disappear after a few hours use.

The Oxysafe flame sensing and flue blockage safety system.

For your safety, this appliance is fitted with a flue blockage safety device which will shut down the appliance in the event of abnormal flue conditions. **This device is NOT a substitute for an independently mounted Carbon Monoxide detector.**

The device will also automatically shut off the gas supply to the fire if the pilot flame goes out due to lack of oxygen or for any other reason.

If this device starts to repeatedly shut off the gas, get expert advice.

This device incorporates a probe which senses that the heat from the pilot flame is correct. If this probe is cool, the device will prevent any gas flow unless the control knob is held in at the ignition position.

If, for any reason, the flames go out when the fire is hot or if the fire is turned off when hot, always **wait at least three minutes before attempting to relight.**

To light the fire.

Depress the control knob and SLOWLY rotate it anticlockwise to the pilot ignition position. A 'click' will be heard as the integral piezo operates. A flame should appear at the pilot. Keep the control knob depressed and hold the pilot ignition position for five seconds. When the control knob is released the pilot flame should remain lit. If a flame does not appear at the pilot then turn the control knob clockwise to the 'OFF' position and repeat the above.

When the pilot burner is operating properly, gradually turn the control knob anti-clockwise to 'HIGH' position. (Depress the knob slightly to get past the pilot ignition position). The main burner should now light.

Depress the control knob slightly to release from the 'HIGH' position and turn back (clockwise) to 'LOW'. While turning, the burner flames should gradually become lower but remain alight. Depress the control knob slightly to release from the 'LOW' position and turn back (clockwise) to the Pilot ignition position. The main burner should

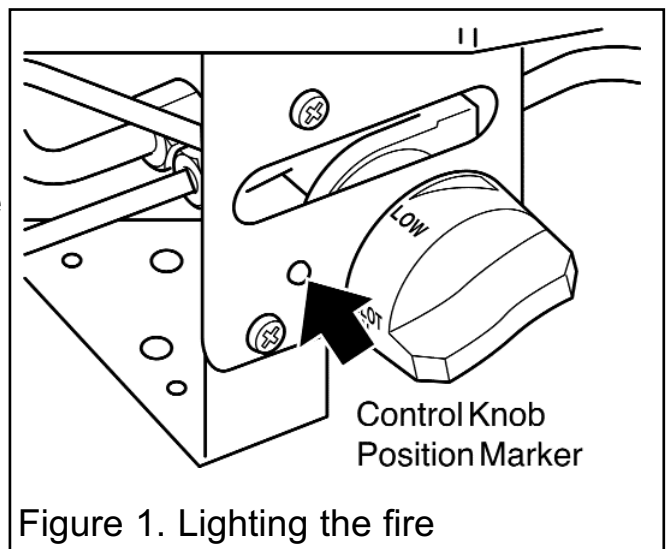

Figure 1. Lighting the fire

OWNER GUIDE

extinguish but the pilot should remain alight. Depress the control knob slightly and turn back (clockwise) to turn OFF. This will extinguish the pilot.

While cooling, the ceramic fuel effect may make some crackling noises. This is quite normal.

- If the flames go out while setting the control, repeat the full lighting procedure.
- If the flames repeatedly go out have the fire serviced.
- Please note. When first turned on the flames will appear predominantly blue. The ceramic fuel effect will take time to warm up. Although some glow will be seen after approximately ten minutes, the full visual effect will only be apparent after a somewhat longer time.
- The appliance will operate to its maximum potential if the flue is primed during the first 20 – 30 minutes of operation. To do this, simply turn the control knob to its 'HIGH' setting. This will also burn off any carbon deposits that may have formed during previous operations.
- If operating the appliance for long periods it is beneficial occasionally to change the settings. This will also help to remove any carbon deposits that may form during operation.

Lighting with a taper.

(See figure 2).

In the unlikely event of failure of the ignition spark, the pilot can be lit by a taper or long spill. Insert the taper or spill between the second and third left hand ceramic fuel effect pieces on the first row.

Operate the control knob as described in the section headed 'To light the fire'.

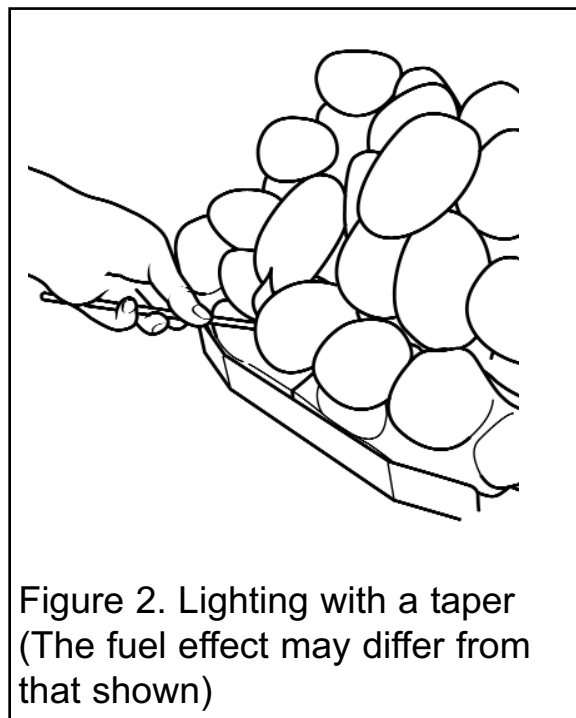

Figure 2. Lighting with a taper
(The fuel effect may differ from that shown)

OWNER GUIDE

CLEANING YOUR FIRE

To maintain the high performance and quality finish of your fire please follow these guidelines:

Before attempting to clean the fire, please remember to turn off the fire and wait for the appliance to cool completely. The fire will retain heat for some time before cleaning can begin.

If any pieces of debris are found in the firebox, have the chimney inspected before further use.

Metal parts.

- Clean the metal parts with a slightly damp cloth and then dry.
- Do not use abrasive cleaners as these will scratch the fire surface.

Ceramic fuel effect pieces and burner compartment walls.

This product uses fuel effect pieces and burner compartment walls containing Refractory Ceramic Fibres (RCF), which are man-made vitreous silicate fibres. Excessive exposure to this material may cause irritation to eyes, skin and respiratory tract. Consequently, it is important to take care when handling these articles to ensure that the release of dust is kept to a minimum.

- Light coatings of soot will usually be burnt off during the normal operation of the fire. Should any soot accumulation become excessive, the fuel effect pieces and walls should be removed from the fire for cleaning.
- Cleaning should be carried out in a well ventilated area or in the open air by gently brushing with the pieces held away from your face so that you avoid inhaling the dust.
- We do not recommend the use of a normal domestic vacuum cleaner which may blow dust back into the air.
- We suggest that you remove the ceramic fuel effect pieces in the reverse order to that shown in the ceramic fuel effect installer and owner guide.

Burner.

Remove any deposits of soot or other foreign matter from the surface of the burner with a dry soft brush. Be careful not to brush any particles into the open slots.

Remove any particles from the slots with a vacuum cleaner fitted with a soft brush attachment. **Do not poke wire, etc. into the slots in the burner.**

OWNER GUIDE

CERAMIC FUEL BED REFITTING

The installer and owner guide for the ceramic fuel effect is separate from this guide. The installer may have attached it to this guide or placed it inside. It is important that the installer and owner guide for the ceramic fuel effect is followed correctly. If replacing the ceramic fuel effect, where a new guide is supplied, follow the installer and owner guide supplied with the replacement fuel effect. Keep the replacement installer and owner guide with this owner guide for future reference.

MAINTENANCE

Regular maintenance.

In order to achieve and maintain high levels of personal safety and performance efficiency, it is essential that the opening at the back of the fire and the flue are kept clear of any form of obstruction. It is possible that deposits of mortar or soot could fall and accumulate causing the flue to be blocked or restricted and so preventing proper clearance of dangerous exhaust fumes.

In the United Kingdom it is the law that a landlord must have any gas appliance, flue and pipework which is situated in a tenant's premises checked for safety at least every twelve months by a competent person (In the UK a GAS SAFE REGISTER engineer, Outside of the UK a CORGI or GAS SAFE REGISTER engineer).

We recommend that all gas appliances and their flues, wherever situated, are checked annually.

- **When fitting replacement parts it is important that only approved parts are used for maximum safety.**

Servicing.

IMPORTANT

To help us quickly help you, please try to have the following information available before you contact us:

Type of fire.

Model/Name.

Serial Number.

You will also be asked for the fault, problem or request plus your Post Code.

- If you wish to replace any of the ceramic fuel effect pieces, spare parts are available nationwide via the 'interpart stockist network'. For your local stockist consult Yellow pages under Central Heating.
- **When fitting replacement parts it is important that only approved parts are used for maximum safety.**

